

CHEMICAL PUMPS SINCE 1992



GENERAL
CATALOGUE

2025 | 2026

COMPANY PRESENTATION P. 4

MAG DRIVE CENTRIFUGAL PUMPS | INTRODUCTION P. 13



Mag-drive centrifugal pumps **HTM PP/PVDF** P. 14



Self-priming mag-drive centrifugal pumps **HTM SP PP/PVDF** P. 20



Mag-drive centrifugal pumps **HCM PP/PVDF** P. 22



Mag-drive centrifugal pumps **HTM SS AISI 316** P. 24

MAG DRIVE TURBINE PUMPS | INTRODUCTION P. 27



Mag-drive turbine pumps **HTT PP/PVDF** P. 28

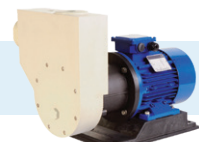

Self-priming mag-drive turbine pumps **HTT-SP PP/PVDF** P. 30



Mag-drive turbine pumps **HTA AISI 316** P. 32

MAG DRIVE ROTARY VANE PUMPS | INTRODUCTION P. 35



Mag-drive rotary vane pumps **HPP/HPF PP/PVDF** P. 36



Mag-drive rotary vane pumps **HTP AISI 316** P. 38

MECHANICAL SEAL CENTRIFUGAL PUMPS | INTRODUCTION P. 41



Mechanical seal centrifugal pumps **HCO PP/PVDF** P. 42

VERTICAL PUMPS | INTRODUCTION

P. 46



Vertical monobloc pumps **HV PP/PVDF max L=1000 mm** **P. 47**

Vertical centrifugal pumps **HVL PP/PVDF max L=2000 mm** **P. 49**

Vertical mag-drive pumps **HTM-V PP/PVDF** **P. 52**

Vertical cantilever pumps **PVA AISI 316** **P. 53**

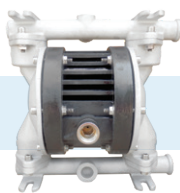

Air-operated double diaphragm pumps **HAOD** **P. 54**

ATEX PUMPS FOR POTENTIALLY EXPLOSIVE ATMOSPHERES

P. 57



ATEX PUMPS AISI 316 **P. 57**



ATEX PUMPS PP/PVDF **P. 58**



ACCESSORIES **P. 60**

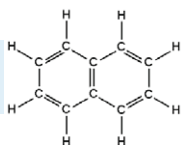

CHEMICAL COMPATIBILITY CHART **P. 66**

All the data indicated in this catalogue are pure indicative and can be changed without prior notice.



OUR COMPANY

GemmeCotti srl has been designing and manufacturing **chemical pumps for acids and dangerous liquids since 1992**, when its founders started their own company after considerable experience in pump design and production. Over the years, GemmeCotti has created a **wide of industrial pumps designed and manufactured by its experienced team of experts**. We are now **specialized in magnetic drive pumps, mechanical seal pumps and vertical pumps**. **GemmeCotti pumps are used worldwide for many applications** including the chemical and petrochemical industries, oil refineries, electroplating, the production of printed circuits, electronic photography, military applications, water treatment, biotechnology, paper and textile mills, sugar plants, food processing, dairies and many more.

GemmeCotti Group includes three companies: GemmeCotti srl, Armek srl and Gemme Plast srl. Armek Srl is GemmeCotti's international subsidiary. **Gemme Plast** is a company part of the GemmeCotti Group **specialized in the injection moulding of plastic materials**. **Armek Srl** is an **international subsidiary** of the Italian company GemmeCotti Srl.

OUR MISSION

GemmeCotti is **dedicated to the continuous improvement of the quality and performance of our pumps**. We aim to become our customers' trusted and preferred supplier for chemical pumps for acids and dangerous liquids. We want to **offer the best products and the best service possible** with an **extremely reduced delivery time**.

OUR VALUES

The values that have guided the company from the beginning are: the quality of the pumps and their materials, the competence, availability and courtesy of the employees who meet the customer's needs and the constant desire to offer the **best service in terms of price/quality and delivery time of the pumps**.



SALES AND AFTER-SALES SERVICE

GemmeCotti offers to customers a complete sale and after-sale service. **Our customer service helps them during the whole sales process**, from the pump selection, throughout all the purchasing procedure, as well as **technical assistance in case of pump repair and spare-part supply** even after the standard warranty period. For every pump supplied there is a complete kit of spare parts available in stock.

QUALITY MANAGEMENT SYSTEM ISO 9001:2015

We are dedicated to quality, as can be seen by the fact that we have been **ISO 9001 certified since 2007**. Recently our Quality Management System has been updated to the new ISO 9001:2015, making us one of the first companies in Italy to be certified to the new quality standards. This is a clear proof of **our dedication to constant improvement and desire to offer high-quality service and products**.

GemmeCotti is constantly becoming more and more efficient and the customer satisfaction is always our priority. Our main desire is to meet the customers' expectations and offer them the best support and top-level products. **We aim to continuously improve every business process**: from the technical and production department, to the marketing and sales office. Every aspect has been developed and organized so that the company can be competitive and flexible on the pump market and can maintain the position of leading supplier of chemical pumps.



*The quality of the pumps
and of their materials.
The competence,
availability and courtesy
of the employees.*



PUMPS PRODUCTION

GemmeCotti's first aim is to understand the customers' requirements and supply the best product to fit their needs. The sales and technical office are **able to select the right pump model and the recommended materials** for the requested application using our **company's know-how** together with **up-to-date software tools**. Once chosen, the pump with the selected configuration can be manufactured.

All the parts of the pumps come from **qualified Italian suppliers** and they are checked and machined carefully by **highly skilled GemmeCotti personnel** to assure the compliance to the technical constructive drawings. The construction materials of GemmeCotti pumps are of the highest quality and they are suitable to resist corrosion and to handle most of the existing chemicals. All the thermoplastic parts are produced by GemmeCotti's sister company Gemme Plast through injection moulding.

The assembly process takes place in our workshop where we carry out a **step-by-step inspections of each pump**. When the pumps are ready, **we test them one by one** using our new and modern test bench to check the performances and their proper functioning before shipping them to the customer.

Our well-stocked warehouse has most of the parts of our standard pumps to satisfy the urgent requests of our customers for pumps and spare parts in a timely fashion.

PUMPS DESIGN

GemmeCotti's technical office and research & development department are continuously involved in the **design of new pumps and the improvement of the existing ones**. Using CAD softwares we make 3D drawings of all the pump parts and pump assembly and then we use the finite element method FEM to perform structure analysis in order to assure structural resistance and strength.

All the pumps are designed following four main objectives: have a **reliable high-tech design, work and withstand the hardest conditions, be chemically resistant and suitable to operate with corrosive and aggressive liquids**, guarantee a **long-lasting service with minimum maintenance**. Our engineers are constantly involved in new projects and in the design of new pumps according to what the market of chemical pumps requires and to the customers' needs.

We are able to offer more than 500 pump variations for meeting a wide range of applications but, if requested, we can also customize our standard pumps according to the customer's preferences.



OUR ENVIRONMENTAL COMMITMENT

Environmental sustainability has increasingly become a priority, and given its undeniable importance, here at GemmeCotti, we are undertaking a series of targeted initiatives to **reduce our environmental impact and promote a sustainable approach**. In our small way, we are particularly keen on actively contributing to protecting the environment and raising awareness among our staff so that they can take positive action within the company and in their daily lives.

At the end of 2023, we permanently moved to our new headquarters and the construction of this new factory provided an opportunity to change perspectives and start adopting measures to minimize the environmental impact of our company.

Another significant step towards greater sustainability was the installation of 140 solar panels. We have implemented a **photovoltaic system to produce clean, renewable energy**, and also to become **self-sufficient in energy production** for our daily activities and the construction of our chemical pumps.



QUALITY MADE IN ITALY

GemmeCotti pumps are entirely manufactured on our premises and they are **100% MADE IN ITALY**. They are **designed, assembled and tested in our workshop** by highly skilled personnel, while the pump parts are made and machined by our **Italian suppliers**, who are all located in the area near our company.

This is the reason why, for us, the suppliers play an important role in the quality of the pumps. We choose and select them through a strict qualification process and we keep a close relationship with them in order to ensure the highest quality of each pump part and consequently of the complete pump assembly.

The Italian origin has always been considered a guarantee of product quality and value, due to the long experience and technical skills of Italian workers. We are proud to carry on this tradition and to supply top-quality industrial pumps in more than 90 countries around the world. Our customers can count on a product which meets mechanical excellence standards at a competitive price with the assurance of Italian origin.



GEMMECOTTI HISTORY

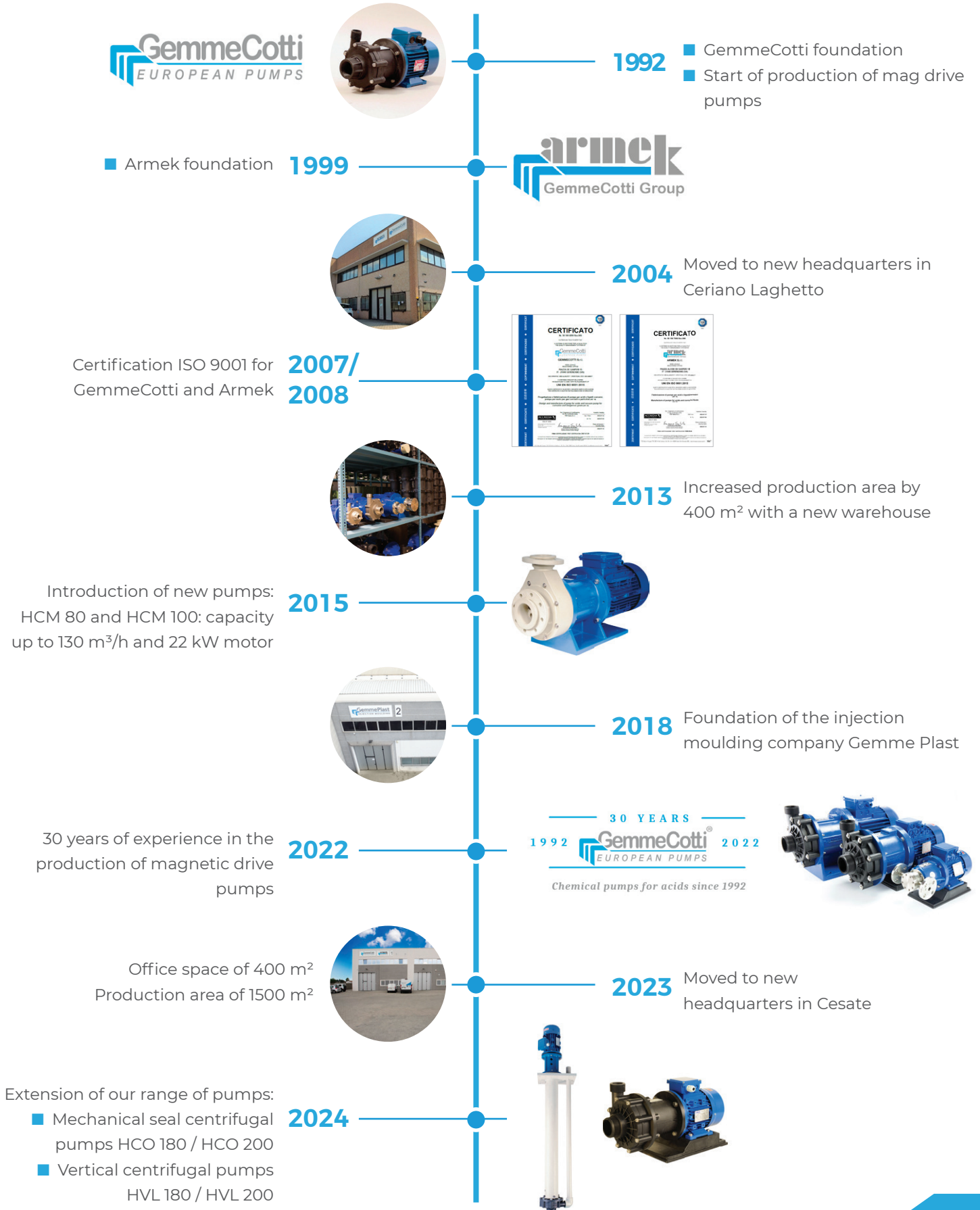

MAIN APPLICATIONS

GemmeCotti supplies a wide range of pump systems for industrial processes and OEMs.. We combine competence and experience with customization ensuring the perfect solution for specific industrial applications.

GemmeCotti chemical pumps can be used for many different applications where it is necessary to handle chemicals, acids, dangerous and corrosive liquids.

Among the many industrial fields that use our pumps there are:



CHEMICAL INDUSTRY



GALVANIC INDUSTRY

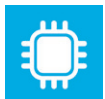

PCB INDUSTRIES



AQUARIUMS



AIR TREATMENT



DETERGENTS



WATER TREATMENTS



OIL & GAS



PHARMACEUTICAL INDUSTRY



CAR WASHING PLANTS



BIOFUEL



TEXTILE INDUSTRY



BOTTLING COMPANIES



LOADING / UNLOADING TANKS



FOOD INDUSTRY



FERTILIZER PRODUCTION

GEMMECOTTI WORLDWIDE

Gemmecotti operates through a **network of authorized distributors worldwide**, ensuring our high-quality chemical pumps are accessible globally. Our pumps are made in **Milano**, in northern Italy, and are supplied to our partners in over 90 countries worldwide, **making us a leading exporter in the industry**. With an annual production exceeding 5,000 pumps, 70% of which are destined for the international market, we have established ourselves as a trusted name in pumps. Contact us for information regarding your local GemmeCotti distributor.





MAGNETIC PUMP: HOW IT WORKS

MAG DRIVE PUMPS

Mag drive pumps have a special seal-less design that is suitable for pumping corrosive and dangerous liquids thanks to the **high chemical resistance** and to the **absence of leakage and emissions**. The **structure is really simple** and it requires **very little maintenance** with consequent savings in terms of repairs, spare parts and machine downtime costs during the pump life.

HOW DOES THE MAGNETIC DRIVE SYSTEM WORK?

In magnetic pumps, there is an **external magnet which is connected to the shaft of the electric motor**. The **synchronous motion** is transmitted from the motor to the rotor (consisting of the internal magnet and the impeller) through the external magnet. **The two magnets never come into contact**, they are moved by the magnetic field only. The impeller connected to the internal magnet spins around a static shaft and the liquid moves through the pump. **The whole hydraulic part is hermetically sealed**: in

the space between the magnets there is a **rear casing** which closes on the pump head and **prevents the pumped liquid from coming out of the pump**.

ADVANTAGES

1. **This special hermetic pump design prevents any leakage of liquid and fugitive emissions**, which in the case of chemicals, corrosive liquids and explosive and inflammable fluids, could be very dangerous for people and the environment. **Our mag-drive pumps fully respect the most stringent environmental and safety guidelines and regulations**. Our special design also prevents the loss of expensive liquids which would add unnecessary costs.
2. **Magnetic pumps are very reliable and need very little maintenance** thanks to their simple design. In normal working conditions, **these pumps can work without any kind of repair for more than a decade**, ensuring a considerable return on the initial investment. In order to safeguard the proper operation of these pumps, the only maintenance required is to periodically check o-rings and bearings, without any other maintenance work.
3. **The coupling is very easy because there is no need for motor/pump alignment**.

The **robust design of GemmeCotti magnetic pumps means that they can be used in the demanding work conditions** of most industrial sectors. **This technology ensures great safety** when used for pumping hazardous liquids as acids, bases and solvents, for this it is ideal for applications in the chemical, petrochemical, pharmaceutical, electronic and galvanic sectors, which require high quality and safety standards. It is important to remember that the usage of magnetic pumps implies paying particular attention to the operating conditions: this type of pumps can't transfer liquids with solids. **The liquid must be clean, without solids in suspension** (max. quantity of solids: max 2% - max 1mm).

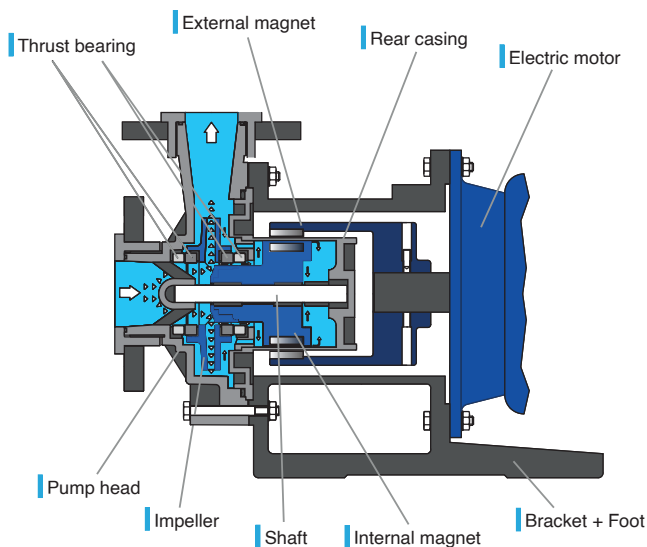



MAG-DRIVE CENTRIFUGAL PUMPS

SEAL-LESS MAG DRIVE CENTRIFUGAL PUMPS

In seal-less magnetic drive centrifugal pumps, the external magnet is directly connected to the motor shaft and it transmits the torque to the internal magnet.

The magnetic field created produces a rotation without physical contact between the parts so the impeller spins and moves the fluid. The rear casing is placed between the two magnet joints and it hermetically closes the hydraulic part from the motor.

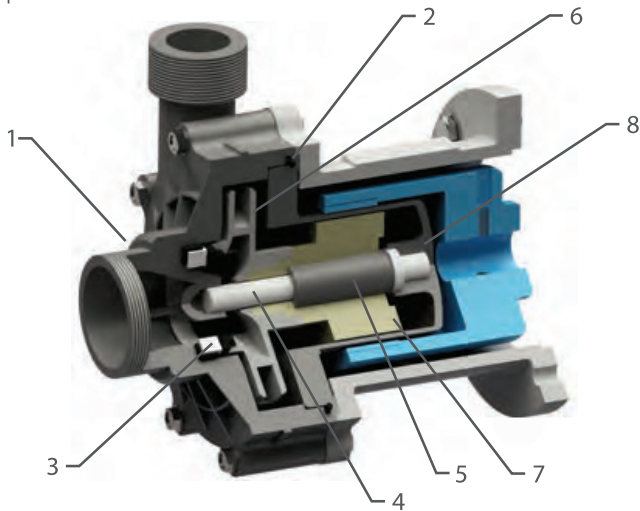

GemmeCotti can supply four different models of mag drive centrifugal pumps:

HTM PP/PVDF

- Thermoplastic pumps made of PP or PVDF.
- Capacity up to 130 m³/h.
- Head up to 48 mlc.
- Injection molded parts.

HTM SP PP/PVDF

- Self-priming pumps made of PP or PVDF.
- Capacity up to 25 m³/h.
- Head up to 22 mlc.

HCM PP/PVDF

- Thermoplastic pumps made of PP or PVDF.
- Capacity up to 130 m³/h.
- Head up to 48 mlc.
- Pump head machined from a block.

HTM SS 316

- Metallic pumps made of stainless steel AISI 316.
- Capacity up to 32 m³/h.
- Head up to 24 mlc.

MATERIALS IN CONTACT WITH THE LIQUID

PART NUMBER - DESCRIPTION	CENTRIFUGAL PUMPS			
	HTM PP/PVDF	HTM SP	HCM	HTM SS 316
1 - PUMP HEAD	PP or PVDF	PP or PVDF	PP or PVDF	AISI 316
2 - O-RING	EPDM or VITON	EPDM or VITON	EPDM or VITON	EPDM or VITON
3 - CASING THRUST BUSH	CERAMIC Al ₂ O ₃ + EPDM or VITON	CERAMIC Al ₂ O ₃ + EPDM	CERAMIC Al ₂ O ₃ + EPDM or VITON	PTFEC
4 - SHAFT	CERAMIC Al ₂ O ₃ 99,7%	CERAMIC Al ₂ O ₃ 99,7%	CERAMIC Al ₂ O ₃ 99,7%	HASTELLOY-C 276
5 - BEARINGS	PTFEC	PTFEC	PTFEC	PTFEC
6 - IMPELLER	PP or PVDF	PP or PVDF	PP or PVDF	AISI 316
7 - INTERNAL MAGNET	PP or PVDF + NdFeB	PP or PVDF + NdFeB	PP or PVDF + NdFeB	AISI 316 + SmCo
8 - REAR CASING	PP or PVDF	PP or PVDF	PP or PVDF	AISI 316



THERMOPLASTIC MAG-DRIVE CENTRIFUGAL PUMPS

MAIN FEATURES

Mag drive centrifugal pumps series **HTM PP/PVDF** are made of thermoplastic materials (**Polypropylene** and **PVDF**) and are suitable for highly corrosive liquids. Thanks to the **innovative mag drive system**, pumps model HTM PP/PVDF reduce the risks of leakage and emissions and the maintenance costs. The transmission of the motion occurs through magnetic joints without any mechanical seal and **this design guarantees the maximum safety and efficiency**. The pumped liquid has to be clean and without solids in suspension.

- **Materials available:** PP / PVDF.
- **Materials in contact with the liquid;** casing and impeller: PP/PVDF; o-ring: EPDM (standard for PP pumps); VITON (standard for PVDF pumps); static shaft: ceramic Al₂O₃ 99,7 %; Bushing PTFEC.
- **Max flow:** 130 m³/h; **Max head** 48 mlc.
- **Temperature:** PP: max 70°C – PVDF: max 90°C.
- **Max viscosity:** 200 cSt.
- **Pressure rating:** NP 6 at 20°C.
- High torque magnetic coupling NdFeB standard.
- Suitable for high corrosive liquids.
- Under head use.
- Suitable for continuous use.

ADVANTAGES

- Zero leakage and emissions.
- No mechanical seal.
- High torque magnetic coupling.
- Perfect solution for clean liquids.
- No motor/pump alignment.
- Long-term savings.
- Limited periodic maintenance.
- Safe and reliable.

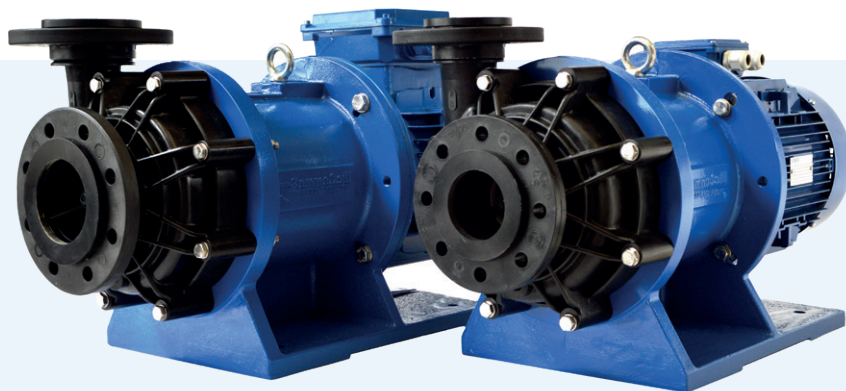

OPTIONAL

- Flanges available (DIN or ANSI).
- Dry-running protection.
- Baseplate.
- HTM pumps are available also for **NEMA motors** and with **NPT connections**.
- Available in **ATEX version** for zone 2 II 3G (mod. EM-C PP/PVDF).

STANDARD

- BSP threaded In and Out connections.
- Direct starting motor.

PERFORMANCE CURVES 50Hz - 2900 RPM - SIZES FROM HTM 4 TO HTM 100

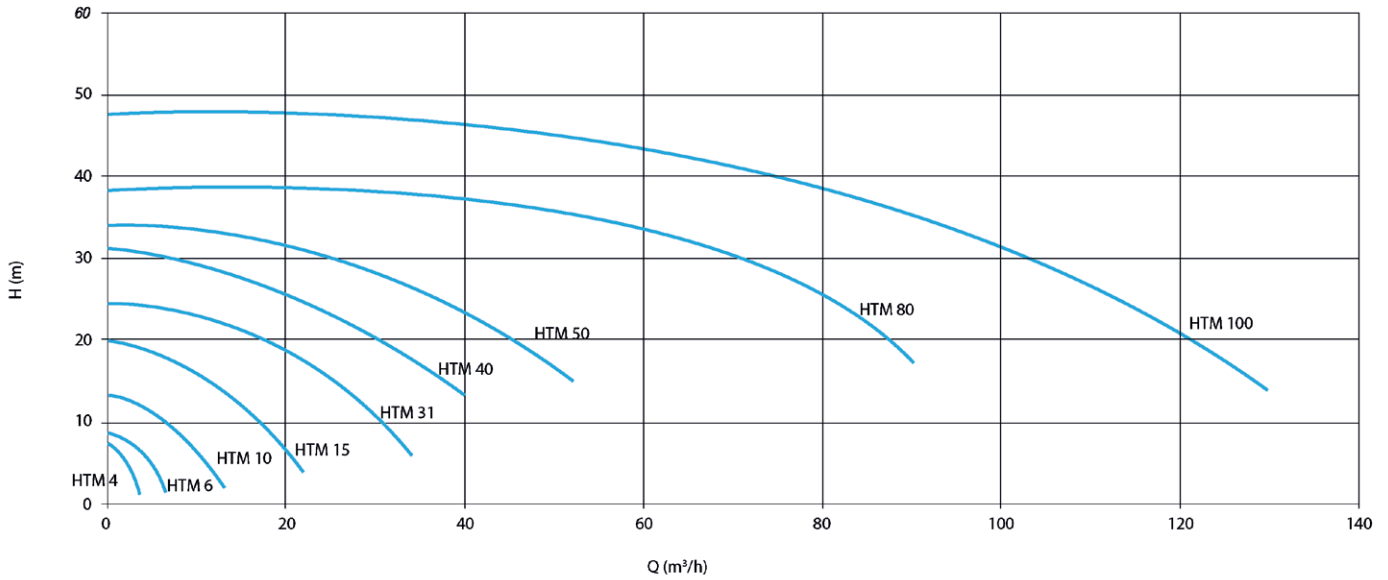

HTM PP/PVDF TECHNICAL DATA

PUMP SIZE	MATERIAL	Q MAX		H MAX		SUCTION CONNECTION	DISCHARGE CONNECTION	PUMP WEIGHT (kg)		SUITABLE MOTOR POWER (kW) 2900 rpm	MOTOR FLANGE AND FRAME
		50Hz (m³/h)	60Hz (USGPM)	50Hz (m/c)	60Hz (ft)			PP	PVDF		
HTM 4	PP- PVDF	3.5	16	7	33	1" FEMALE	1/2" MALE	0.95	1.05	0.12	56 B - B3 / B5
HTM 6	PP- PVDF	6.5	30	8.5	42	1" FEMALE	3/4" MALE	1.6	1.8	0.25	63 B - B3 / B5
HTM 10	PP- PVDF	13	68	14	58	1" 1/2 FEMALE	1" MALE	2.6	2.9	0.55 1.1	71 2B - B3 / B5 80 B - B3 / B5
HTM 15	PP- PVDF	23	125	20	90	2" MALE	1" 1/2 MALE	5.8	6.6	1.1 1.5 2.2	80 B - B3 / B5 90 S - B3 / B5 90 L - B3 / B5
HTM 31	PP- PVDF	35	185	24	115	2" 1/2 MALE	2" MALE	8.0	8.9	2.2 3 4	90 L - B3 / B5 100 L - B3 / B5 112 M - B3 / B5
HTM 40	PP- PVDF	42	215	31	150	3" MALE	2" 1/2 MALE	19.7	21.3	3 4	100 L - B3/B5 112 M - B3/B5
HTM 50	PP- PVDF	43	220	33	160	3" MALE	2" 1/2 MALE	32.2	35	5.5 7.5 9.2	132 S2A - B5 132 S2B - B5 132 MA - B5
HTM 80	PP- PVDF	90	352	38	123	DN 80	DN 65	42	44	7.5 11 15 18.5	132 S2 - B5 160 M2A - B5 160 M2B - B5 160 L2 - B5
HTM 100	PP- PVDF	130	528	48	148	DN 100	DN 80	40	45	11 15 18.5 22	160 M2A - B5 160 M2B - B5 160 L2 - B5 180 M2 - B5



THERMOPLASTIC MAG-DRIVE CENTRIFUGAL PUMPS



HTM 4-6-10 PP/PVDF

- **Materials available:** PP / PVDF.
- **Max flow:** 13 m³/h.
- **Max head** 14 mlc.
- **Max temperature:** PP 70°C - PVDF 90°C.
- **Max viscosity:** 200 cSt.
- **System pressure:** NP 6 at 20°C.
- **Standard motor:** 2 Poles 3Phase 50/60 Hz B3 / B5.
- **Special motor upon request.**
- **Connections:** BSP (Flanges or NPT connections upon request).
- **ATEX version:** EM-C PP/PVDF II 3G ZONE 2.

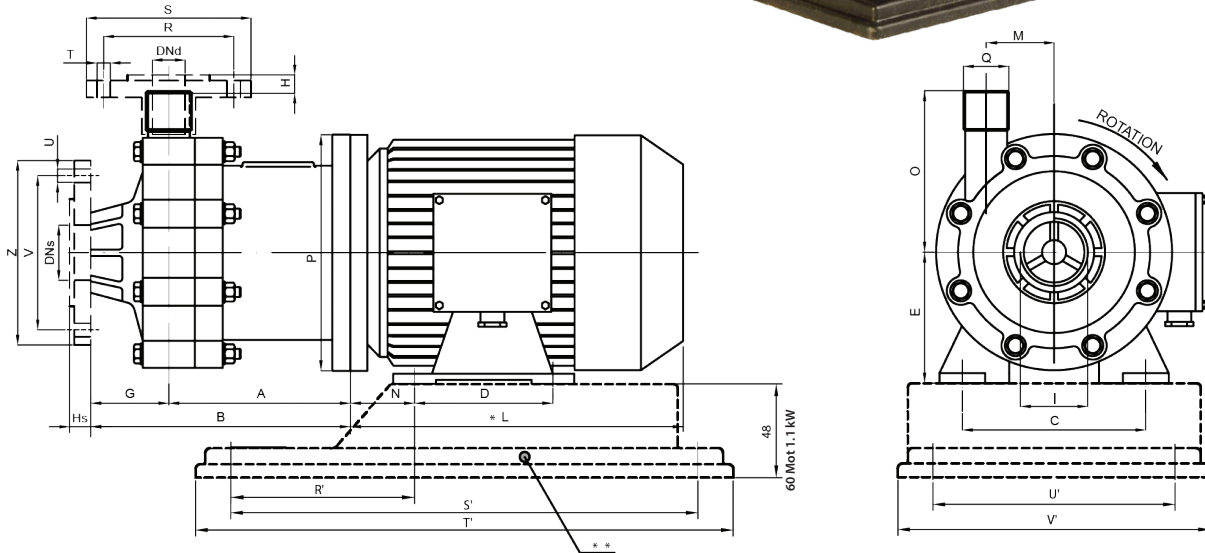
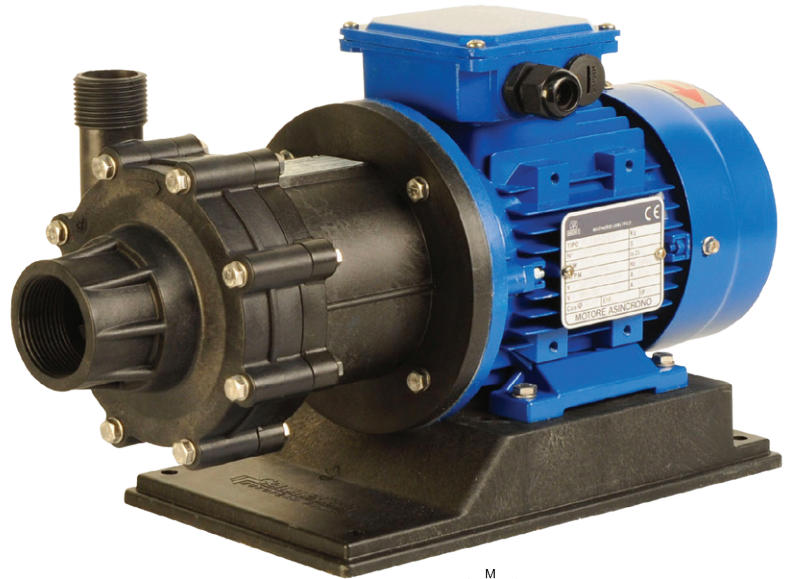

DIMENSIONS - mm -

PUMP TYPE	MOTOR FLANGE B3- B5	KW	A	B	C	D	E	Hs	G	H	I	*L	M	N	O	P	Q	BASEPLATE DIMENSIONS -mm-				
																		R	S	T	U	V
HTM 4	56 B	0.12	76	115	90	71	56	-	39	-	1" FEMALE	176	34	36	80	120	1/2" MALE	94	244	280	130	160
HTM 6	63 B	0.25	85	143	100	80	63	22	59	6	1" FEMALE	191	45	40	98	140	3/4" MALE	102	244	280	130	160
HTM 10	71 2B	0.55	112	180	112	90	71	34	70	5	1" 1/2 FEMALE	215	45	45	100	160	1" MALE	112	244	280	130	160
HTM 10	80 B	1.1	122	190	125	100	80	34	70	5	1" 1/2 FEMALE	232	45	50	100	200	1" MALE	120	302	350	157	205

* Different according to the manufacturer. ** OPTIONAL UPON REQUEST: DIN or ANSI Flanges and Baseplates.
NOTE: DIRECTION OF ROTATION IS COUNTER CLOCKWISE AS SEEN WHEN FACING THE MOTOR.
PUMPS AVAILABLE THREADED OR FLANGED.

FLANGES DIN PN 10 DIMENSIONS - mm -

PUMP TYPE	R	S	T	U	V	Z	DNs	DNd
HTM 4	-	-	-	-	-	-	-	-
HTM 6	75	105	14	14	85	115	25	20
HTM 10	85	115	14	18	110	150	40	25

HTM 15-31-40 PP/PVDF

- **Materials available:** PP / PVDF.
- **Max flow:** 42 m³/h.
- **Max head** 31 mlc.
- **Max temperature:** PP 70°C - PVDF 90°C.
- **Max viscosity:** 200 cSt.
- **System pressure:** NP 6 at 20°C.
- **Standard motor:** 2 Poles 3Phase 50/60 Hz B3 / B5.
- **Special motor upon request.**
- **Connections:** BSP (Flanges or NPT connections upon request).
- **ATEX version:** EM-C PP/PVDF II 3G ZONE 2.

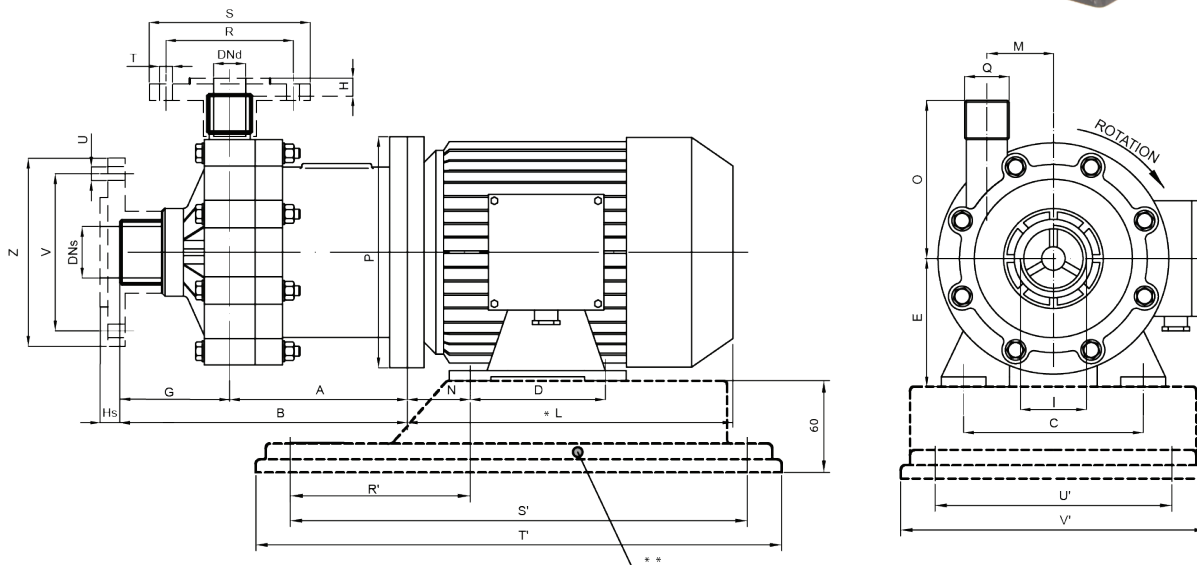
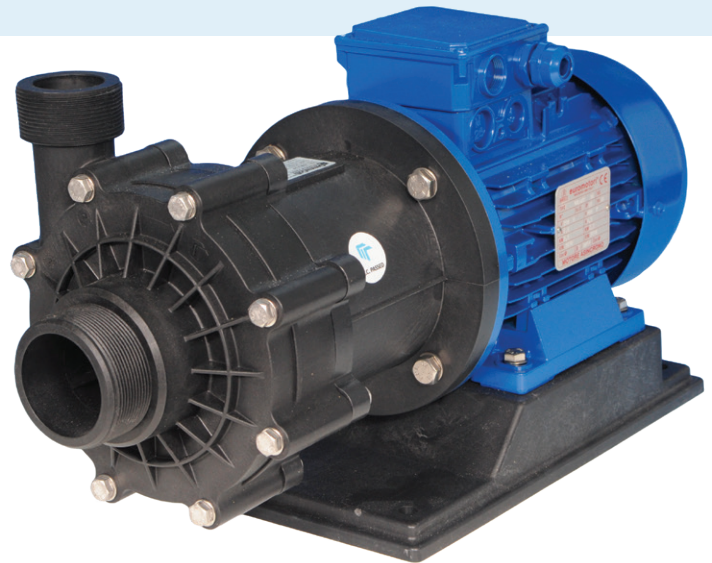

DIMENSIONS - mm -

PUMP TYPE	MOTOR FLANGE B3 - B5	KW																BASEPLATE DIMENSIONS - mm -				
			A	B	C	D	E	G	Hs	H	I	*L	M	N	O	P	Q	R	S	T	U	V
HTM 15	80 B	1.1	151	231	125	100	80	80	14	13	2" MALE	232	66	50	135	200	1" 1/2 MALE	120	302	350	157	205
HTM 15	90 S	1.5	161	241	140	100	90	80	14	13	2" MALE	256	66	56	135	200	1" 1/2 MALE	132	302	350	157	205
HTM 15	90 L	2.2	161	241	140	125	90	80	14	13	2" MALE	280	66	56	135	200	1" 1/2 MALE	132	302	350	157	205
HTM 31	90 L	2.2	183	274	140	125	90	91	14	13	2" 1/2 MALE	280	66	56	140	200	2" MALE	132	302	350	157	205
HTM 31	100 L	3	203	294	160	140	100	91	14	13	2" 1/2 MALE	315	66	63	140	250	2" MALE	140	352	400	202	250
HTM 31	112 M	4	203	294	190	140	112	91	14	13	2" 1/2 MALE	325	66	70	140	250	2" MALE	156	352	400	202	250
HTM 40	100 L	3	228	320	160	140	100	92	10	10	3" MALE	315	82.5	63	170	250	2" 1/2 MALE	140	352	400	202	250
HTM 40	112 M	4	228	320	190	140	112	92	10	10	3" MALE	325	82.5	70	170	250	2" 1/2 MALE	156	352	400	202	250

FLANGES DIN PN 10 DIMENSIONS - mm -

PUMP TYPE	R	S	T	U	V	Z	DNs	DNd
HTM 15	110	153	18	18	125	168	50	40
HTM 31	125	168	18	18	145	188	65	50
HTM 40	145	188	18	18	160	203	80	65

* Different according to the manufacturer. ** OPTIONAL UPON REQUEST: DIN or ANSI Flanges and Baseplates.
 NOTE: DIRECTION OF ROTATION IS COUNTER CLOCKWISE AS SEEN WHEN FACING THE MOTOR.
 PUMPS AVAILABLE THREADED OR FLANGED.



THERMOPLASTIC MAG-DRIVE CENTRIFUGAL PUMPS

HTM 50 PP/PVDF

- **Materials available:** PP / PVDF.
- **Max flow:** 43 m³/h.
- **Max head** 33 mlc.
- **Max temperature:** PP 70°C - PVDF 90°C.
- **Max viscosity:** 200 cSt.
- **System pressure:** NP 6 at 20°C.
- **Standard motor:** 2 Poles 3Phase 50/60 Hz B5.
- **Special motor upon request.**
- **Connections:** BSP (Flanges or NPT connections upon request).
- **ATEX version:** EM-C PP/PVDF II 3G ZONE 2.

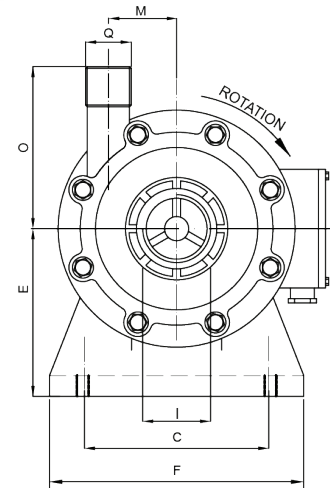
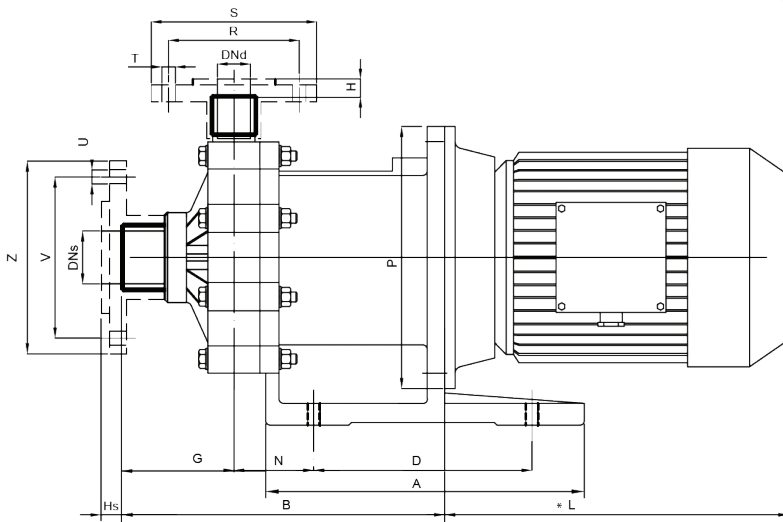

DIMENSIONS - mm -

PUMP TYPE	MOTOR FLANGE B5	kW	A	B	C	D	E	F	G	H	Hs	I	*L	M	N	O	P	Q
HTM 50	132 S2A	5.5	365	339	216	250	192	274	92	10	10	3" MALE	383	82.5	98	170	300	2" 1/2 MALE
HTM 50	132 S2B	7.5	365	339	216	250	192	274	92	10	10	3" MALE	421	82.5	98	170	300	2" 1/2 MALE
HTM 50	132 MA	9.2	365	339	216	250	192	274	92	10	10	3" MALE	475	82.5	98	170	300	2" 1/2 MALE

* Different according to the manufacturer * OPTIONAL UPON REQUEST: DIN or ANSI Flanges.
 NOTE: DIRECTION OF ROTATION IS COUNTER CLOCKWISE AS SEEN WHEN FACING THE MOTOR.
 PUMPS AVAILABLE THREADED OR FLANGED.

FLANGES DIN PN 10 DIMENSIONS - mm -

PUMP TYPE	R	S	T	U	V	Z	DNs	DNd
HTM 50	145	188	18	18	160	203	80	65

HTM 80-100 PP/PVDF

- **Materials available:** PP / PVDF.
- **Max flow:** 130 m³/h.
- **Max head** 48 mlc.
- **Max temperature:** PP 70°C - PVDF 90°C.
- **Max viscosity:** 200 cSt.
- **System pressure:** NP 6 at 20°C.
- **Standard motor:** 2 Poles 3Phase 50/60 Hz B5.
- **Special motor upon request.**
- **Connections:** DIN or ANSI Flanges.
- **ATEX version:** EM-C PP/PVDF II 3G ZONE 2.

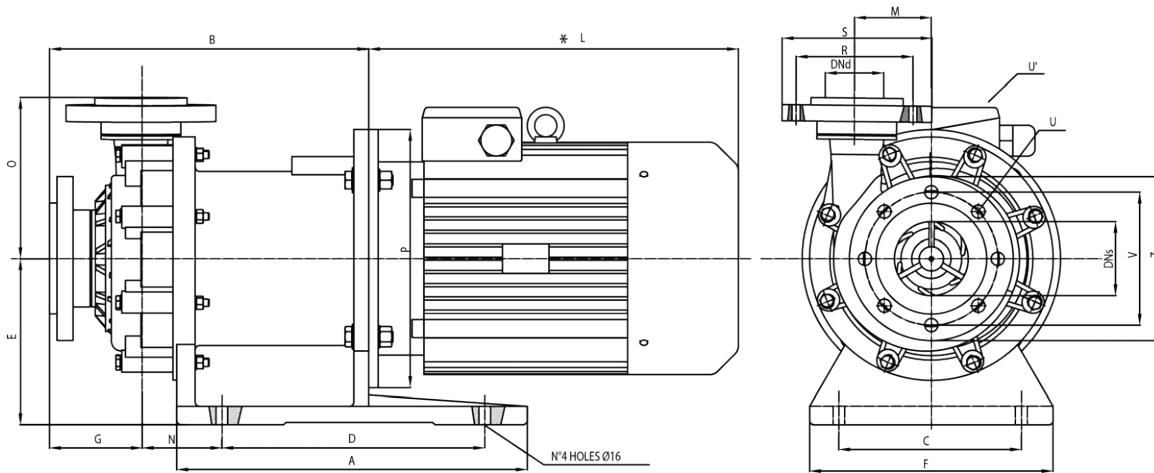
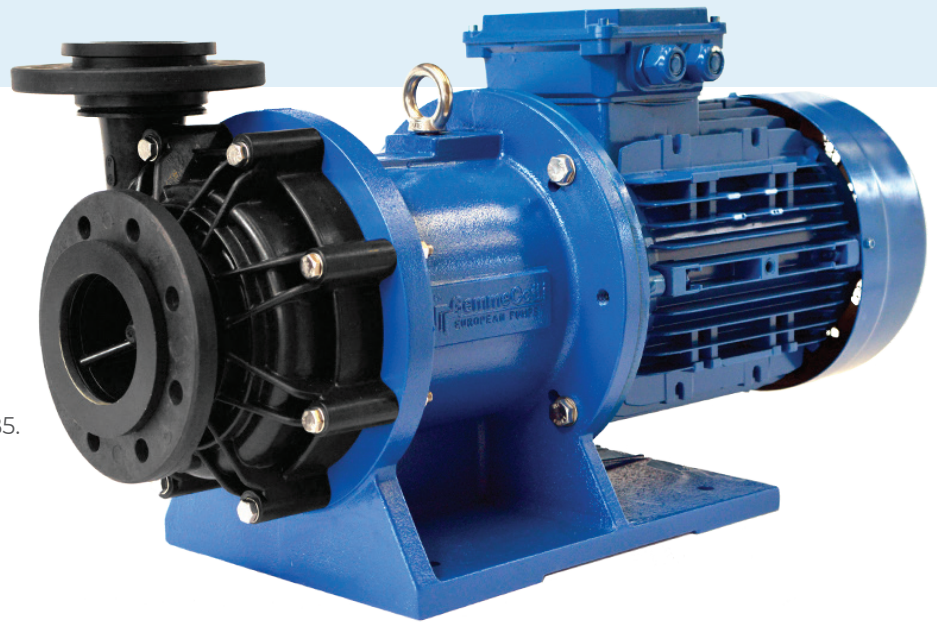

DIMENSIONS - mm -

PUMP TYPE	MOTOR FLANGE B5	kW	A	B	C	D	E	F	G	*L	M	N	O	P
HTM 80	132S2	7.5	475	433	250	360	225	330	126	421	103	104	215	300
HTM 80	160M2A	11	475	433	250	360	225	330	126	510	103	104	215	350
HTM 80	160M2B	15	475	433	250	360	225	330	126	510	103	104	215	350
HTM 80	160L2	18.5	475	433	250	360	225	330	126	554	103	104	215	350
HTM 100	160M2A	11	475	435	250	360	225	330	124	510	103	104	217	350
HTM 100	160M2B	15	475	435	250	360	225	330	124	510	103	104	217	350
HTM 100	160L2	18.5	475	435	250	360	225	330	124	554	103	104	217	350
HTM 100	180M2	22	475	435	250	360	225	330	124	595	103	104	217	350

FLANGES DIN PN 10 DIMENSIONS - mm -

PUMP TYPE	R	S	U	U'	V	Z	DNs	DNd
HTM 80	145	188	n° 8 holes ø 18	n° 4 holes ø 18	160	200	80	65
HTM 100	160	200	n° 8 holes ø 18	n° 8 holes ø 18	180	220	100	80

* Different according to the manufacturer * HTM 80-100: standard pumps supplied DIN Flanges.
NOTE: DIRECTION OF ROTATION IS COUNTER CLOCKWISE AS SEEN WHEN FACING THE MOTOR.



THERMOPLASTIC SELF-PRIMING MAG-DRIVE CENTRIFUGAL PUMPS



HTM SP pumps combine the typical features of our mag drive centrifugal pumps with the self-priming capability. **At sea level** these pumps **can prime up to 6 meters**. HTM SP pumps are made of **Polypropylene (PP)**, a thermoplastic material that ensures the best resistance to most chemicals. Thanks to the **innovative seal-less magnetic drive system**, the pump model HTM SP guarantees the maximum safety and efficiency, **reducing the risks of leakage and emissions in the environment and the maintenance costs**. The pumped liquid has to be clean, without solids in suspension.

MAIN FEATURES

- **Materials available:** PP / PVDF.
- **Materials in contact with the liquid:** Pump housing: PP or PVDF; Impeller: PP or PVDF; O-ring: EPDM (standard for PP pumps) / VITON (standard for PVDF pumps); Static shaft: ceramic Al₂O₃ 99.7%; Bearing: PTFEC.
- **Capacity** up to 25 m³/h.
- **Head** up to 22 m.
- **Max Temperature:** PP: 70°C - PVDF: 90°C.
- **Max viscosity:** 20 cSt.
- **Pressure rating:** NP 6 at 20°C.
- Self-priming up to 6m at sea level.
- Suction connection available in 3 welded configurations (frontal, on the right and on the left).

STANDARD

- BSP threaded In and Out connections.
- Direct starting motor.

OPTIONAL

- Baseplate.
- Available in ATEX version for zone 2 II 3G (mod. EM-C SP PP/PVDF).

PERFORMANCE CURVES 50Hz - 2900 RPM

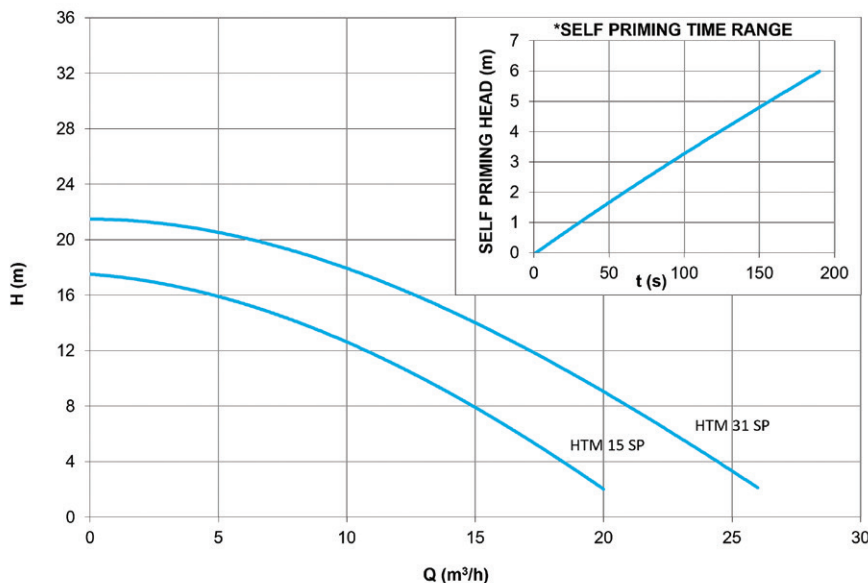

HTM 31 SP

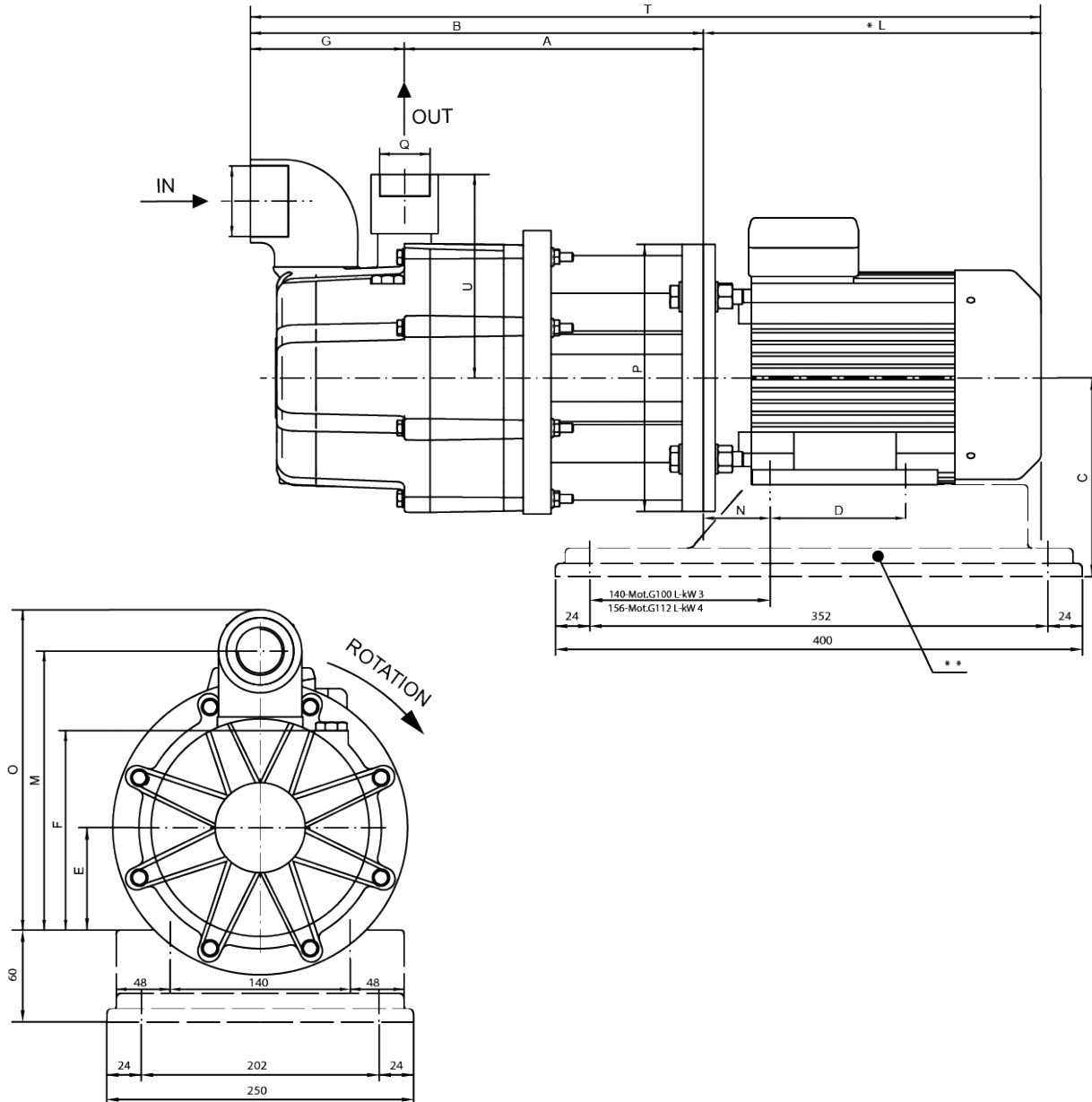

DIMENSIONS - mm -

PUMP TYPE	MOTOR FLANGE B3/B5	kW	A	B	C	D	E	F	G	I	L	M	N	O	P	Q	T	U
HTM 31 SP	100 L	3	280.5	425	160	140	100	191	144.5	1" 1/2 FEMALE	317	265.5	63	304.5	250	1" FEMALE	742	190.5
HTM 31 SP	112 M	4	280.5	425	160	140	100	191	144.5	1" 1/2 FEMALE	317	265.5	63	304.5	250	1" FEMALE	742	190.5

* Different according to the manufacturer ** OPTIONAL UPON REQUEST: Baseplates.

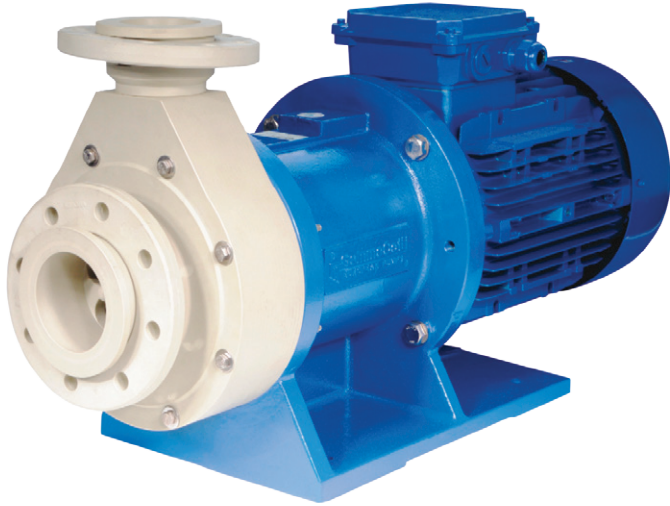

Mag drive centrifugal pumps series HCM are made of thermoplastic materials (**Polypropylene or PVDF**) and, thanks to their strong and resistant structure, they are suitable for high corrosive fluids and heavy duty applications. The pump casing is machined from a solid block for a great resistance in terms of pressure and temperature and the transmission of the motion occurs through magnetic joints without any mechanical seal. This magnetic drive system guarantees the maximum safety and efficiency **reducing risks of leakage and emissions**.

TYPICAL APPLICATIONS

- High corrosive liquids.
- Toxic, noxious and carcinogenic liquids.

OPTIONAL

- Dry-running protection device.

MAIN FEATURES

- **Materials available:** PP / PVDF.
- **Materials in contact with the liquid:** pump head and impeller PP or PVDF; o-ring EPDM (standard for PP pumps) VITON (standard for PVDF pumps); shaft: ceramic Al₂O₃ 99,7%; bushing PTFEC.
- **Max capacity:** 130 m³/h.
- **Max head:** 48m.
- **Max temperature:** PP: 70°C –PVDF: 90°C.
- **Viscosity:** 200 cSt.
- **Max pressure:** NP 6 at 20°C.
- Flanged or threaded connections according to the pump size.
- Strong structure, maximum resistance to corrosive liquids.

PERFORMANCE CURVES 50Hz - 2900 RPM

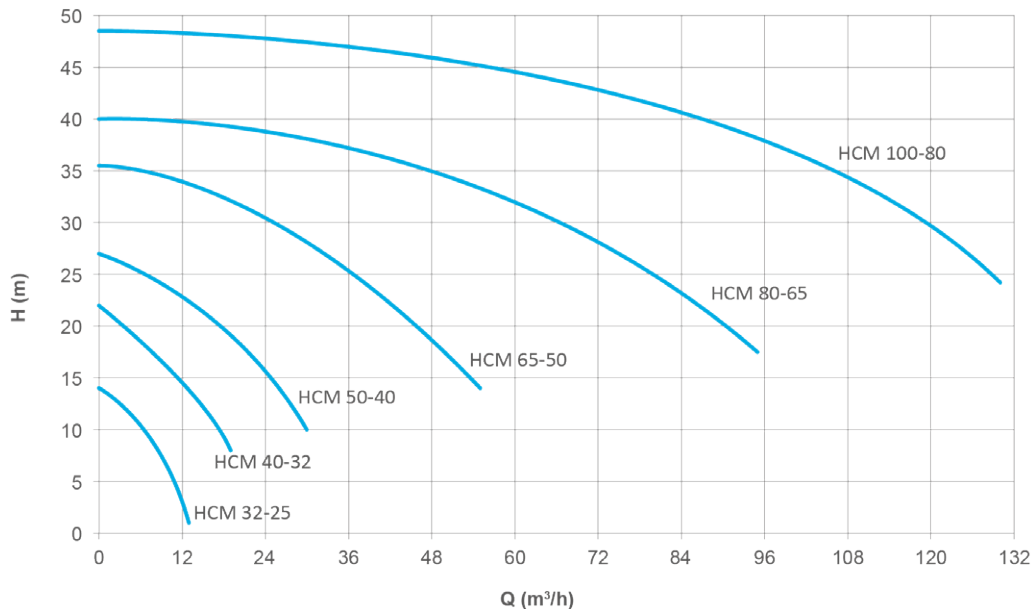

HCM 32-25 / 40-32 / 50-40 / 65-50L PP/PVDF

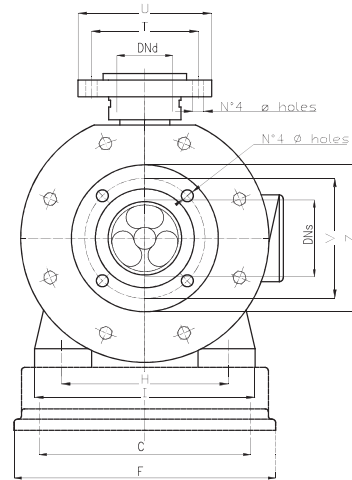
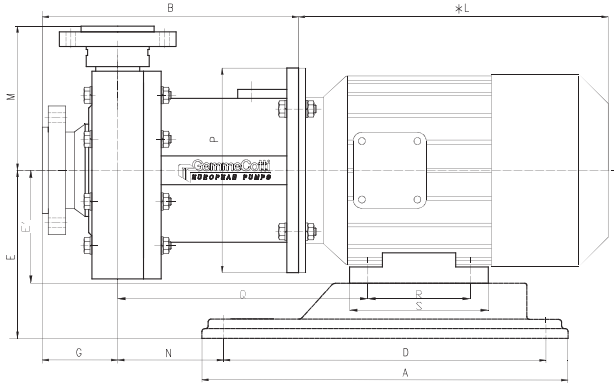

DIMENSIONS - mm -

PUMP TYPE	MOTOR FLANGE B3-B5	kW	A	B	C	D	E	E'	F	G	H	I	*L	M	N	P	Q	R	S	FLANGES DIN PN 10 - DIMENSIONS - mm						
																				T	U	V	Z	DNs	DNd	Ø holes
HCM 32-25	71	0.55	280	187	130	244	119	71	160	75	112	140	260	115	45	158.5	157	90	110	85	117	100	143	32	25	14
HCM 40-32	80 90	1.1 1.5	350	236 246	146	302	140 150	80 90	205	85	125 140	160 170	280	142	80 84	200	200 216	100	130 153	100	143	110	153	40	32	14
HCM 50-40	90 100	2.2 3	350 400	268	146 202	302 352	150 160	90 100	205 250	84	140 160	180 200	280 316	149	108 127	200 250	240 267	125 140	160 182	110	153	125	168	50	40	18
HCM 65-50-L	112	4	400	331	202	352	172	112	250	103	190	230	324	171	142	250	298	140	195	125	168	145	188	65	50	18

* Different according to the manufacturer

HCM 65-50H / 80-65 / 100-80 PP/PVDF

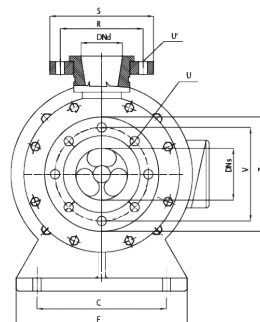
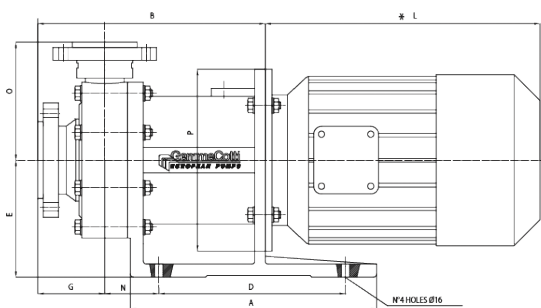

DIMENSIONS - mm -

PUMP TYPE	MOTOR FLANGE B5	kW	A	B	C	D	E	F	G	*L	N	O	P	FLANGES DIN PN 10 - DIMENSIONS - mm							
														R	S	U	U'	V	Z	DNs	DNd
HCM 65-50-H	132 132 132	5.5 7.5 9	365	351	216	250	192	274	103	383 421 421	98	171	300	125	168	n° 4 Ø18 holes	n° 4 Ø18 holes	145	188	65	50
HCM 80-65	132S2 160M2A 160M2B 160L2	7.5 11 15 18.5	475	430	250	360	225	330	130	421 510 510 554	106	234	300 350 350 350	145	188	n° 8 Ø18 holes	n° 4 Ø18 holes	160	200	80	65
HCM 100-80	160M2A 160M2B 160L2 180M2	11 15 18.5 22	475	436	250	360	225	330	126	510 510 554 595	105	263	350	160	200	n° 8 Ø18 holes	n° 8 Ø18 holes	180	220	100	80

* Different according to the manufacturer



Mag drive centrifugal pumps series HTM SS are made of **AISI 316** and are suitable for hydrocarbons solvents and dangerous liquids. Thanks to the **innovative mag drive design**, pumps model HTM SS reduce the risks of leakage and emissions and the maintenance costs. The transmission of the motion occurs through magnetic joints without any mechanical seal. This design guarantees the **maximum safety and efficiency**. The pumped liquid has to be clean and without solids in suspension. Pumps series HTM SS 316 are also available in **ATEX version** for zone **1 and 2** (pump model EM-C).

MAIN FEATURES

- **Materials available:** AISI 316.
- **Materials in contact with the liquid:** casing and impeller: stainless steel AISI 316; o-ring: VITON; bushing: PTFE/CARBON; shaft: Hastelloy C276.
- **Max flow:** 32 m³/h; **Max head:** 24 m.
- **Max Temperature:** 160°C.
- **Max viscosity:** 200 cSt.
- **Pressure rating:** NP 16 at 20°C.

STANDARD

- Threaded in and out connections.

OPTIONAL

- Explosion proof motor.
- Flanges available (DIN or ANSI).
- Dry-running protection device.
- Baseplate.
- Overload switch.
- Available in ATEX version for zone 1 II2G and zone 2 II 3G (pump mod. EM-C AISI 316).

PERFORMANCE CURVES 50Hz - 2900 RPM

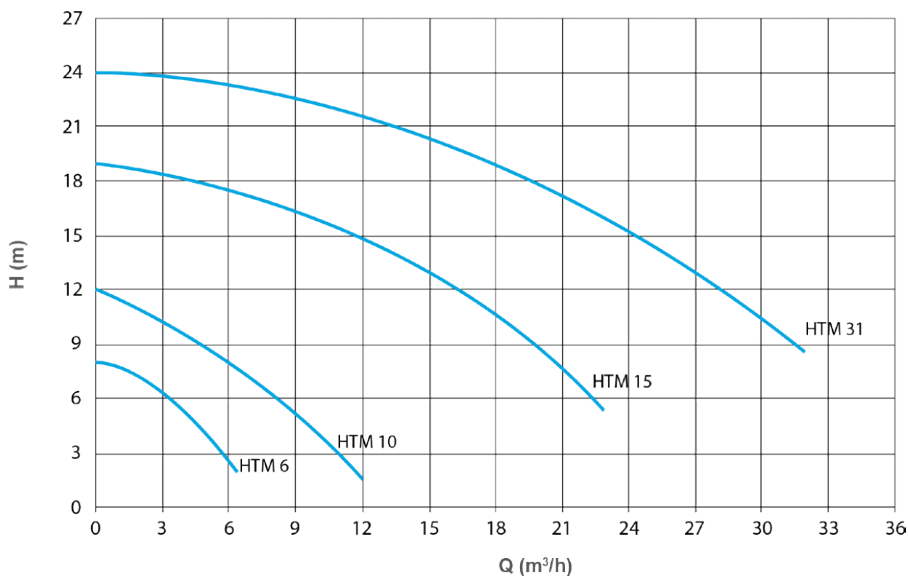

HTM SS 316 TECHNICAL DATA

PUMP SIZE	MATERIAL	Q MAX		H MAX		SUCTION CONNECTION	DISCHARGE CONNECTION	PUMP WEIGHT (kg)	SUITABLE MOTOR POWER (kW) 2900 rpm	MOTOR FLANGE AND FRAME
		50Hz (m³/h)	60Hz (USGPM)	50Hz (m/c)	60Hz (ft)					
HTM 6	AISI 316	6	30	8	42	1" FEMALE	3/4" MALE	6.2	0.55	71 B - B3 / B5
HTM 10	AISI 316	12	50	12	52	1 1/2" FEMALE	1" MALE	11.7	1.1	80 B - B3 / B5
HTM 15	AISI 316	23	117	19	85	2" MALE	1 1/2" MALE	17	1.5 2.2	90 S - B3 / B5 90 L B3 / B5
HTM 31	AISI 316	32	180	24	110	2 1/2" MALE	2" MALE	20	2.2 3 4	90 L - B3 / B5 100 L B3 / B5 112 M B3 / B5

HTM 6-10 SS316 • EM-C 6-10 SS316 (ATEX VERSION)

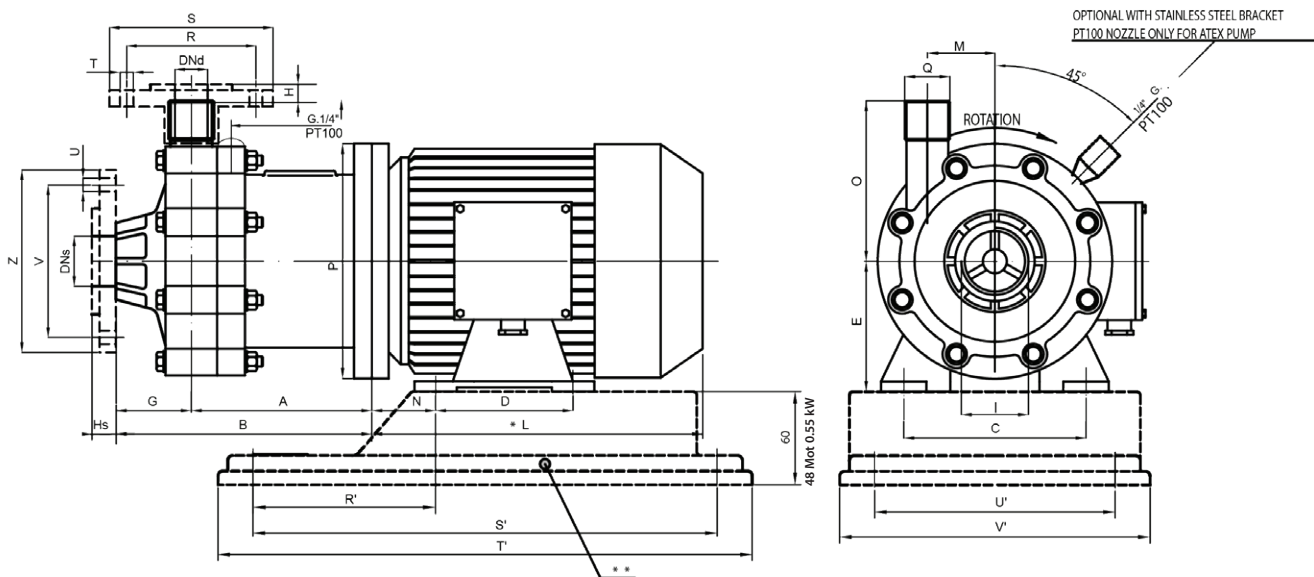

DIMENSIONS - mm -

PUMP TYPE	MOTOR FLANGE B3 - B5	kW	A	B	C	D	E	Hs	G	H	I	*L	M	N	O	P	Q	BASEPLATE DIMENSIONS -mm-				
																		R'	S'	T'	U'	V'
HTM 6 SS316	71 B	0.55	137	194	112	90	71	24	57	4	1" FEMALE	215	46	45	89	160	3/4" MALE	102	244	280	130	160
HTM 10 SS316	80 B	1.1	145	214	125	100	80	20	69	8	1 1/2" FEMALE	232	44	50	98	200	1" MALE	120	302	350	157	205

FLANGES DIMENSIONS - mm -

PUMP TYPE	R	S	T	U	V	Z	DNs	DNd
HTM 6 SS316	75	105	14	14	85	115	25	20
HTM 10 SS316	85	115	14	18	110	150	40	25

* Different according to the manufacturer ** OPTIONAL UPON REQUEST: DIN or ANSI Flanges and Baseplates.
NOTE: DIRECTION OF ROTATION IS COUNTER CLOCKWISE AS SEEN WHEN FACING THE MOTOR.
PUMPS AVAILABLE THREADED OR FLANGED.



HTM 15-31 SS316 • EM-C 15-31 SS316 (ATEX VERSION)

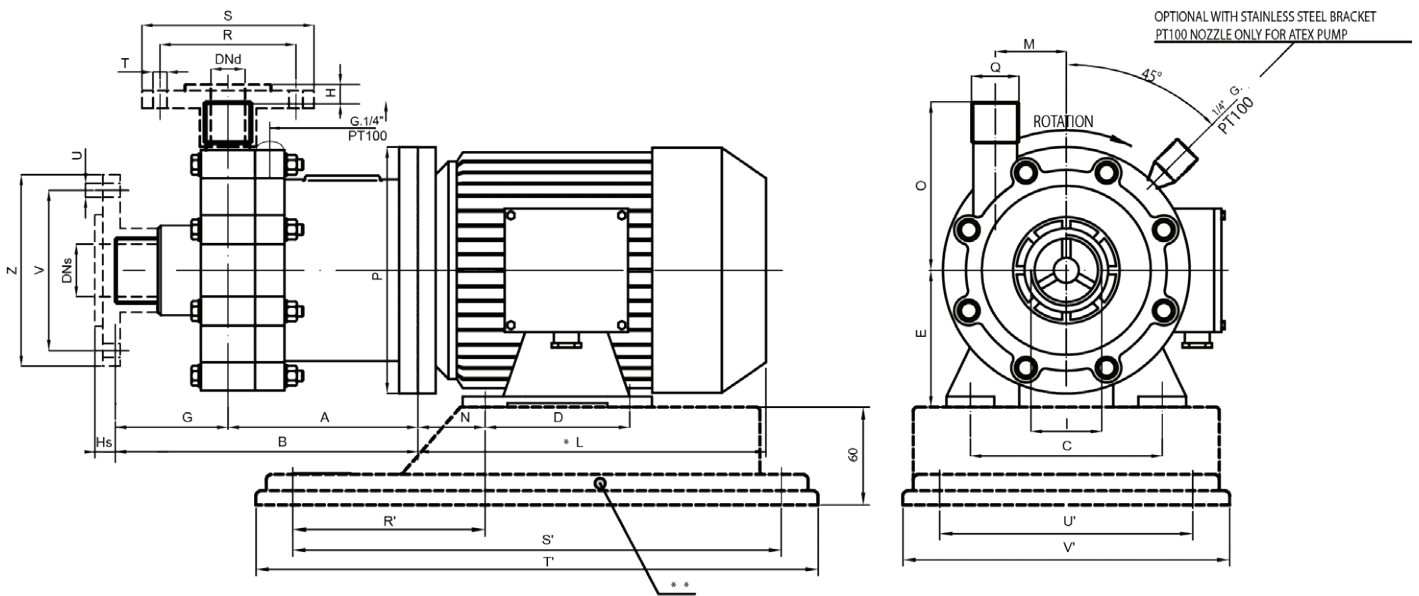

DIMENSIONS - mm -

PUMP TYPE	MOTOR FLANGE B3 - B5	kW	A	B	C	D	E	Hs	G	H	I	*L	M	N	O	P	Q	BASEPLATE DIMENSIONS -mm-				
																		R'	S'	T'	U'	V'
HTM 15 SS316	90 S	1.5	176	256	140	100	90	6	80	4	2" MALE	255	66	56	135	200	1 1/2" MALE	132	302	350	157	205
HTM 15 SS316	90 L	2.2	176	256	140	125	90	6	80	4	2" MALE	280	66	56	135	200	1 1/2" MALE	132	302	350	157	205
HTM 31 SS316	90 L	2.2	175	266	140	125	90	6.5	91	5	2" 1/2" MALE	280	66	56	140	200	2" MALE	132	302	350	157	205
HTM 31 SS316	100 L	3	175	266	160	140	100	6.5	91	5	2" 1/2" MALE	316	66	63	140	250	2" MALE	132	302	350	157	205
HTM 31 SS316	112 M	4	175	266	190	140	112	6.5	91	5	2" 1/2" MALE	324	66	70	140	250	2" MALE	132	302	350	157	205

* Different according to the manufacturer ** OPTIONAL UPON REQUEST: DIN or ANSI Flanges and Baseplates.
NOTE: DIRECTION OF ROTATION IS COUNTER CLOCKWISE AS SEEN WHEN FACING THE MOTOR.
PUMPS AVAILABLE THREADED OR FLANGED.

FLANGES DIMENSIONS - mm -

PUMP TYPE	R	S	T	U	V	Z	DNs	DNd
HTM 15 SS316	110	153	18	18	125	168	50	40
HTM 31 SS316	125	168	18	18	145	188	65	50



MAG-DRIVE TURBINE PUMPS

SEAL-LESS MAG DRIVE TURBINE PUMPS

In seal-less magnetic drive turbine pumps, the external magnet is directly connected to the motor shaft and it transmits the torque to the internal magnet. The magnetic field created produces a rotation without physical contact between the parts and the turbine spins and moves the fluid. The rear casing is placed between the two magnet joints and it hermetically closes the hydraulic part from the motor.

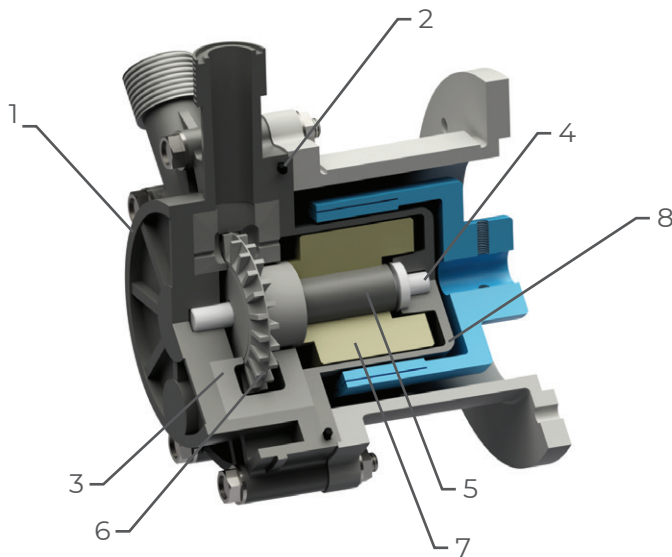

GemmeCotti supplies three different models of mag drive turbine pumps:

HTT PP/PVDF

- Thermoplastic pumps made of PP or PVDF.
- Capacity up to 9 m³/h.
- Head up to 48 mlc.

HTT-SP PP/PVDF

- Thermoplastic pumps made of PP or PVDF.
- Capacity up to 6 m³/h.
- Head up to 24 mlc.
- Machined from a block.
- Self-priming up to 5 m.

HTA AISI 316

- Metallic pumps made of stainless steel AISI 316.
- Capacity up to 7 m³/h.
- Head up to 76 mlc.

MATERIALS IN CONTACT WITH THE LIQUID

PART NUMBER - DESCRIPTION	TURBINE PUMPS		
	HTT	HTT-SP	HTA
1 - PUMP HEAD	PP or PVDF	PP or PVDF	AISI 316
2 - O-RING	EPDM or VITON	EPDM or VITON	EPDM or VITON
3 - FRONT AND REAR DISC	PP or PVDF	PP or PVDF	PTFEC
4 - SHAFT + RING	CERAMIC Al ₂ O ₃ 99,7%	CERAMIC Al ₂ O ₃ 99,7%	HASTELLOY-C 276
5 - BEARING	PTFEC	PTFEC	PTFEC
6 - IMPELLER	PVDF	PVDF	AISI 316
7 - INTERNAL MAGNET	PP or PVDF + NdFeB	PP or PVDF + NdFeB	AISI 316 + SmCo
8 - REAR CASING	PP or PVDF	PP or PVDF	AISI 316

THERMOPLASTIC MAG-DRIVE REGENERATIVE TURBINE PUMPS



STANDARD

- Gas threaded In and Out connections.
- Static shaft in high purity ceramic.
- Chemical resistant PTFE/carbon sleeve bearings.
- High torque magnetic coupling.
- Direct starting motor.

OPTIONAL

- DIN or ANSI 150 flanges available.
- Baseplate.
- Dry-running protection device.
- Available in ATEX version for zone 2II 3G (pump mod. EM-T PP/PVDF).

Mag drive regenerative turbine pumps series **HTT** are made of thermoplastic materials (**Polypropylene-PP** and **PVDF**) and are suitable for pumping high corrosive liquids. Thanks to the innovative mag drive system, pumps model **HTT** **reduce risks of leakage and emissions and the maintenance costs**. The transmission of the motion occurs through magnetic joints without any mechanical seal. This seal-less design guarantees the **maximum safety and efficiency**. The pumped liquid has to be clean and without solids in suspension.

MAIN FEATURES

- **Materials available:** PP / PVDF.
- **Plastic injection moulded.**
- **Materials in contact with the liquid:** casing and rear casing: PP/PVDF; Impeller: PVDF; o-ring: EPDM (standard for PP pumps); VITON (standard for PVDF pumps); shaft: ceramic Al_2O_3 99,7%; bearing: PTFEC.
- **Max flow:** 9 m³/h; **Max head** 48 m.
- **Max Temperature:** PP: max 70°C – PVDF: max 90°C.
- **Max viscosity:** 45 cPs.
- **Pressure rating:** NP 6 at 20°C.
- It handles up to 20% entrained gas.
HTT pump resists cavitation.

PERFORMANCE CURVES 50Hz - 2900 RPM

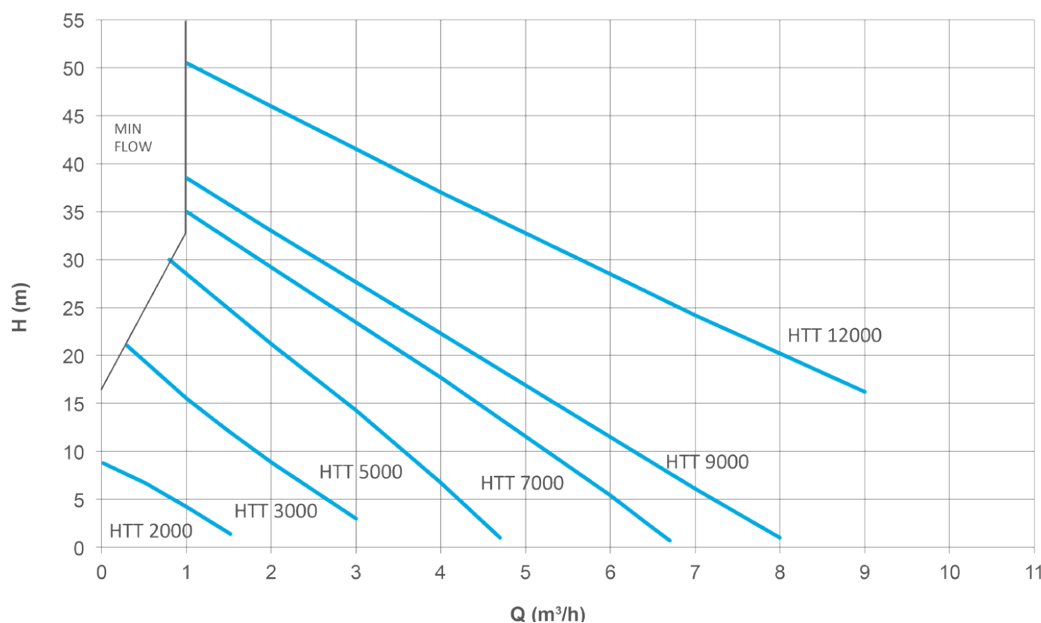

HTT TECHNICAL DATA

PUMP SIZE	MATERIAL	Q MAX		H MAX		SUCTION CONNECTION	DISCHARGE CONNECTION	PUMP WEIGHT (kg)		SUITABLE MOTOR POWER (kW) 2900 rpm	MOTOR FLANGE AND FRAME
		50Hz (m³/h)	60Hz (USGPM)	50Hz (m/c)	60Hz (ft)			PP	PVDF		
HTT 2000	PP- PVDF	1.7	8.8	10	50	1" MALE	1" MALE	2.8	3.8	0.37	71 - B3 / B5
HTT 3000	PP- PVDF	3	15	21	102	1" MALE	1" MALE	2.8	3.8	0.37 0.55	71 - B3 / B5 71 - B3 / B5
HTT 5000	PP- PVDF	5	26	30	140	1" 1/2 MALE	1" 1/2 MALE	8	10	0.75 1.1	80 - B3 / B5 80 - B3 / B5
HTT 7000	PP- PVDF	7	37	36	162	1" 1/2 MALE	1" 1/2 MALE	8	10	1.1 1.5 2.2	80 - B3 / B5 90 S - B3 / B5 90 L - B3 / B5
HTT 9000	PP- PVDF	8	41	36	177	1" 1/2 MALE	1" 1/2 MALE	8	10	2.2 3	90 - B3 / B5 100 - B3 / B5
HTT 12000	PP- PVDF	9	42	48	235	1" 1/2 MALE	1" 1/2 MALE	8	10	3 4	100 - B3 / B5 112 - B3 / B5

HTT 2000 - 3000 - 5000 - 7000 - 12000 PP/PVDF

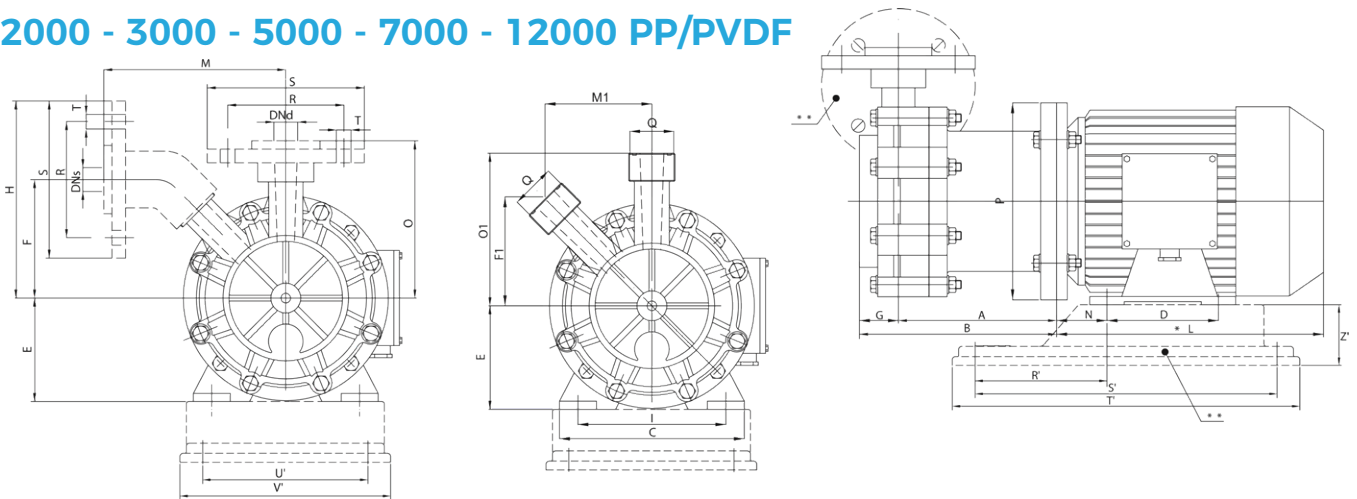

PUMP TYPE	MOTOR FLANGE B3-B5	kW	DIMENSIONS - mm -																	BASEPLATE DIMENSIONS - mm						
			A	B	C	D	E	F	Fl	G	H	I	*L	M	M1	N	O	O1	P	Q	R'	S'	T'	U'	V'	Z'
HTT 2000	71 2A	0.37	118	146	142	90	71	875	78	28	145	112	192	135	78	45	115	110	160	1" MALE	112	244	280	130	160	48
HTT 3000	71 2A 71 2B	0.37 0.55	118	146	142	90	71	86	78	28	145	112	192 215	135	78	45	115	110	160	1" MALE	112	244	280	130	160	48
HTT 5000	80 A 80 B	0.75 1.1	187	221	160	100	80	110	95	34	186	125	215 232	189	95	50	148	135	200	1" 1/2 MALE	120	302	350	157	205	60
HTT 7000	80 B 90 S 90 L	1.1 1.5 2.2	187	221	160 170 170	100 100 125	80 90 90	110	95	34	187	125 140 140	232 255 280	189	95	50 56 56	148	135	200	1" 1/2 MALE	120 120 132	302	350	157	205	60
HTT 9000	90 L2 100 L2	2.2 3	187 207	221 241	170 200	125 140	90 100	110	95	34	186	140 160	280 316	189	95	56 63	148	135	200 250	1" 1/2 MALE	132 140	302 352	350 400	157 202	205 250	60
HTT 12000	100 L 112 M	3 4	207	241	200 230	140	100 112	110	95	34	186	160 190	316 324	189	95	63 70	148	135	250	1" 1/2 MALE	140 156	352	400	202	250	60

FLANGES DIMENSIONS - mm -

PUMP TYPE	R	S	T	DNs	DNd
HTT 2000 - 3000	85	115	14	25	25
HTT 5000 - 7000 - 9000 - 12000	110	153	18	40	40

* Different according to the manufacturer. ** OPTIONAL UPON REQUEST: DIN or ANSI Flanges and Baseplates. NOTE: DIRECTION OF ROTATION IS COUNTER CLOCKWISE AS SEEN WHEN FACING THE MOTOR. PUMPS AVAILABLE THREADED OR FLANGED.



HTT-SP PP/PVDF

THERMOPLASTIC MAG-DRIVE REGENERATIVE TURBINE PUMPS - SELF-PRIMING

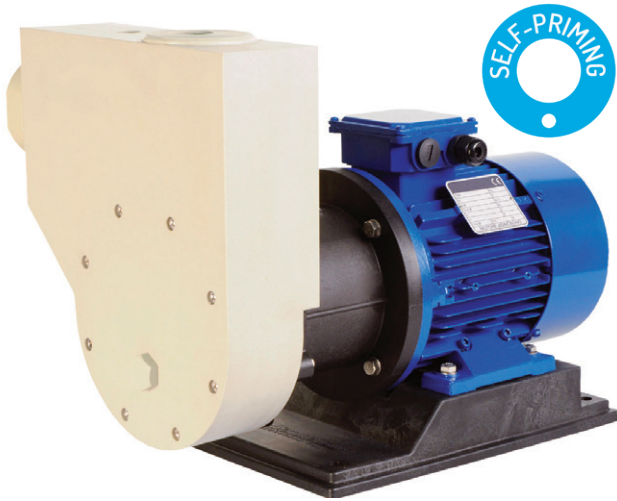

HTT-SP pumps can **prime up to 5 m** with water at ambient temperature. **The casing is made from a PP solid machined block and the impeller in PVDF** for maximum chemical resistance. The casing is machined from a solid block. The impeller in PVDF is self-balanced to eliminate thrust bearing wear and it is separate to minimize the maintenance costs. This kind of pump offers **maximum resistance with standing also external corrosion**. It handles up to 20% entrained gas and resists cavitation.

STANDARD

- High torque magnetic coupling.
- Chemical resistant PTFE/carbon sleeve bearings.
- Direct starting motors.

OPTIONAL

- DIN or ANSI flanges available.
- Baseplate.
- Available in ATEX version for zone 2II 3G (pump mod. EM-T SP PP/PVDF).

MAIN FEATURES

- **Materials available:** PP / PVDF.
- **Materials in contact with the liquid:**
Pump housing: PP or PVDF; Impeller: PVDF; O-ring: EPDM (standard for PP pumps) / VITON (standard for PVDF pumps); Static shaft: ceramic Al₂O₃ 99.7%; Bearing: PTFEC.
- **Max flow:** 6 m³/h; **Max head** 24 mlc.
- **Max Temperature:** PP: 70°C – PVDF: 90°C.

PERFORMANCE CURVES 50Hz - 2900 RPM

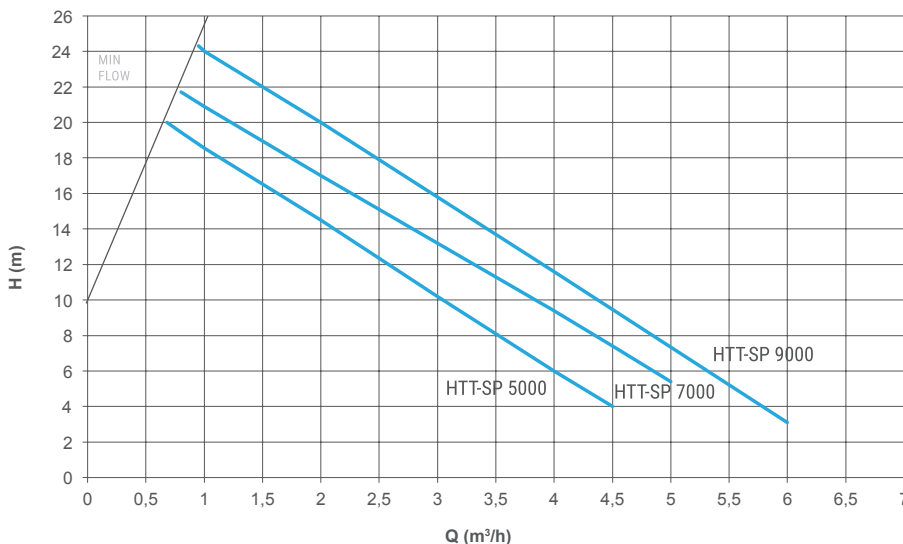

HTT-SP TECHNICAL DATA

PUMP SIZE	MATERIAL	Q MAX		H MAX		SUCTION CONNECTION	DISCHARGE CONNECTION	SUITABLE MOTOR POWER (kW) 2900 rpm	MOTOR FLANGE AND FRAME
		50Hz (m³/h)	60Hz (USGPM)	50Hz (m/c)	60Hz (ft)				
HTT-SP 5000	PP- PVDF	4.5	23	18	90	1" FEMALE	1" FEMALE	0.75 1.1	80 - B3 / B5 80 - B3 / B5
HTT-SP 7000	PP- PVDF	5	27	20	98	1" FEMALE	1" FEMALE	1.1 1.5 2.2	80 - B3 / B5 90 S - B3 / B5 90 L - B3 / B5
HTT-SP 9000	PP- PVDF	6	32	24	110	1" FEMALE	1" FEMALE	2.2 3	90 - B3 / B5 100 - B3 / B5

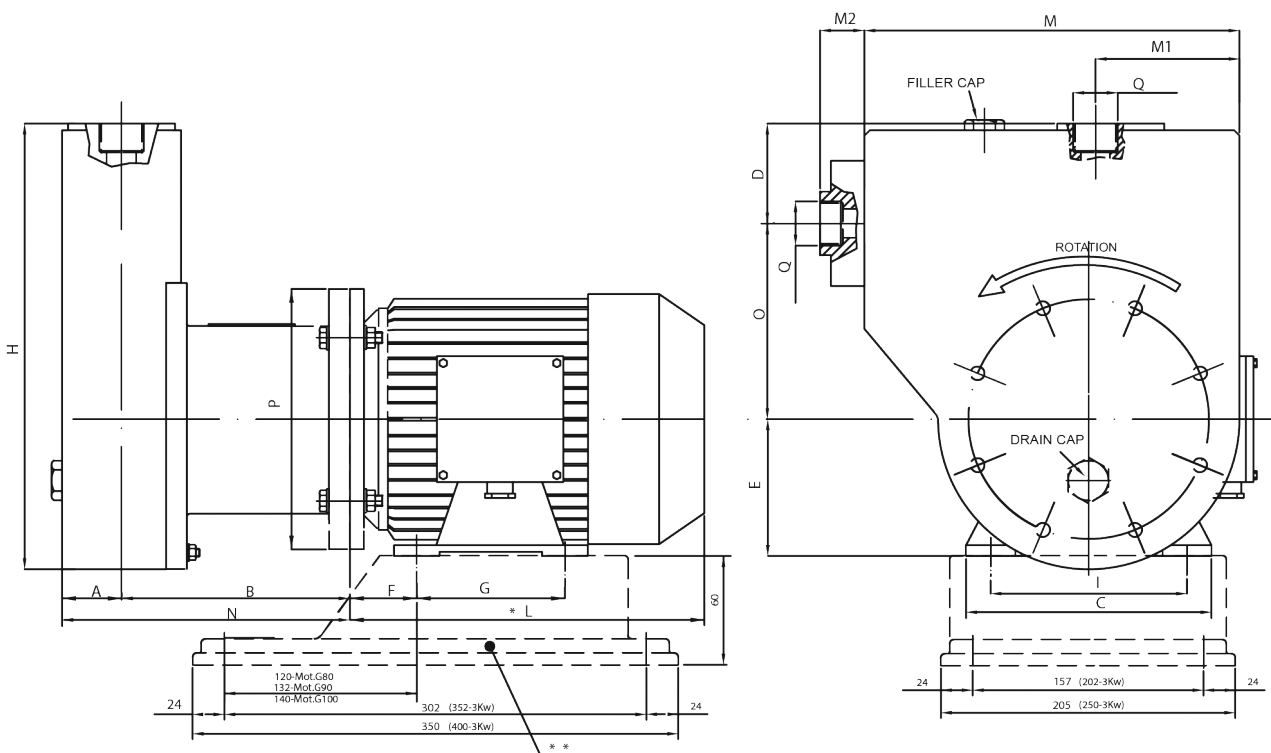

DIMENSIONS - mm -

PUMP TYPE	MOTOR FLANGE B3 - B5	kW	A	B	C	D	E	F	G	H	I	* L	M	M1	M2	N	O	P	Q
HTT-SP 5000	80 2A 80 2B	0.75 1.1	PP = 45 PVDF = 41	175	160	70	80	50	100	325	125	215 232	270	97.5	33	PP = 220 PVDF = 216	147	200	1" FEMALE
HTT-SP 7000	80 2B 90 S 90 L	1.1 1.5 2.2	PP = 45 PVDF = 41	175	160 170 170	70	80 90 90	56	100 100 125	325	125 140 140	232 255 280	270	97.5	33	PP = 220 PVDF = 216	152	200	1" FEMALE
HTT-SP 9000	90 L 100 L	2.2 3	PP = 45 PVDF = 41	186 206	175 200	72	90 100	56 63	125 140	329	140 160	290 315	275	102	37	PP = 231 / PVDF = 227 PP = 251 / PVDF = 247	150	200 250	1" FEMALE

* Different according to the manufacturer. ** OPTIONAL UPON REQUEST: DIN or ANSI Flanges and Baseplates.



METALLIC MAG-DRIVE REGENERATIVE TURBINE PUMPS



Mag drive regenerative turbine pumps series HTA are made of **AISI 316** and are suitable for solvents, hydrocarbons, dangerous and inflammable liquids. Thanks to the innovative mag drive system, pumps model HTA **reduce the risks of leakage and emissions and maintenance costs**. The transmission of the motion occurs through magnetic joints without any mechanical seal. This design guarantees the maximum **hermetic safety and efficiency**. The pumped liquid has to be clean and without solids in suspension. Pumps series HTA are also available in **ATEX version for zone 1 and 2** (pump model EM-T AISI 316).

STANDARD

- Static shaft in HC 276.
- Chemical resistant PTFE/Carbon sleeve bearings standard.
- High torque magnetic coupling.
- Direct starting motors.

OPTIONAL

- DIN or ANSI flanges available.
- Explosion proof motor.
- Dry-running protection device.
- Baseplate.
- Available in ATEX version for zone 1 II2G and zone 2 II 3G (pump mod. EM-T AISI 316).

MAIN FEATURES

- **High head / low flow capability** minimizes by-pass requirements.
 - **Materials available:** AISI 316.
 - **Materials in contact with the liquid:** casing and impeller: stainless steel AISI 316; o-ring EPDM/VITON; bushing: PTFEC; shaft: Hastelloy C276.
 - **Max flow** 7 m³/h; **Max head:** 76 mlc.
 - **Max temperature:** 160°C.
 - **Max viscosity:** 45 cPs.
 - **Pressure Rating** NP 25 at 20°C.
 - Impeller design handles up to 20% entrained gas.
- Ideal for pumping liquefied gas.**

PERFORMANCE CURVES 50Hz - 2900 RPM

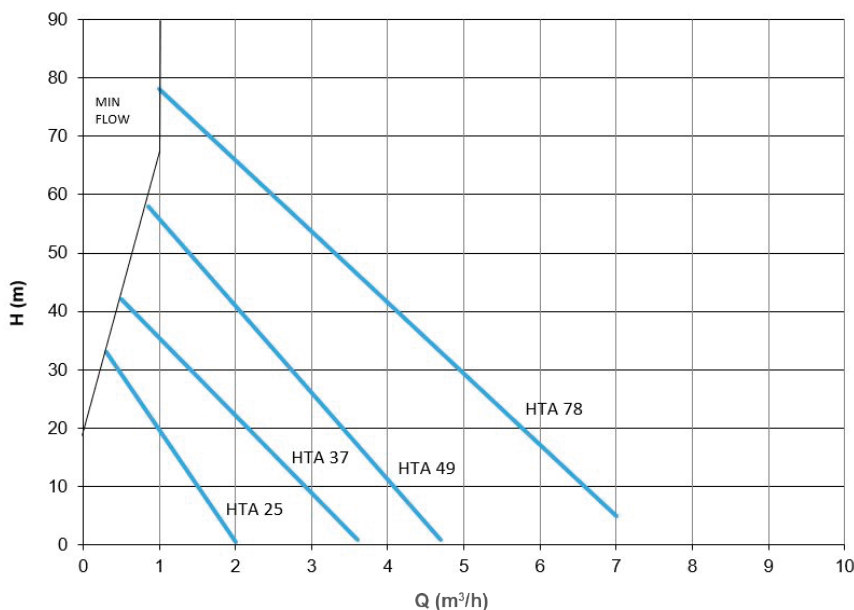

HTA TECHNICAL DATA

PUMP SIZE	MATERIAL	Q MAX		H MAX		SUCTION CONNECTION	DISCHARGE CONNECTION	PUMP WEIGHT (kg)	SUITABLE MOTOR POWER (kW) 2900 rpm	MOTOR FLANGE AND FRAME
		50Hz (m³/h)	60Hz (USGPM)	50Hz (m/c)	60Hz (ft)					
HTA 25	AISI 316	2	10	32	140	3/4" FEMALE	3/4" FEMALE	7.5	1.1	80 - B3 / B5
HTA 37	AISI 316	3.5	19	43	180	3/4" FEMALE	3/4" FEMALE	7.5	1.1 2.2	80 - B3 / B5 90 - B3 / B5
HTA 49	AISI 316	4.7	25	58	235	1" FEMALE	1" FEMALE	14.2	2.2 3	90 - B5 100 - B5
HTA 78	AISI 316	7	36	76	320	1" FEMALE	1" FEMALE	19	3 4	100 - B5 112 - B5

HTA 25-37 SS / EM-T 25-37 SS (ATEX VERSION)

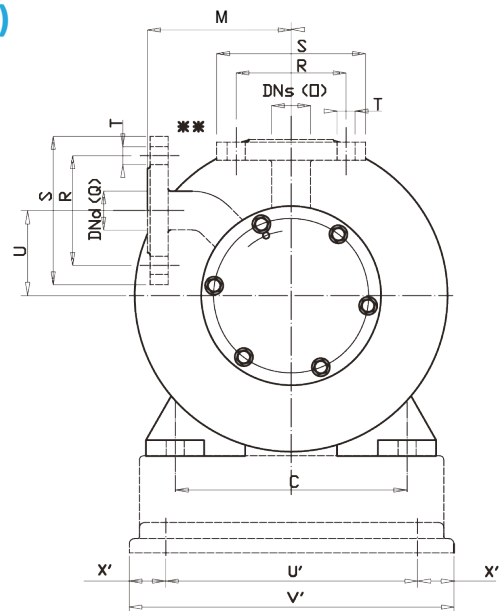
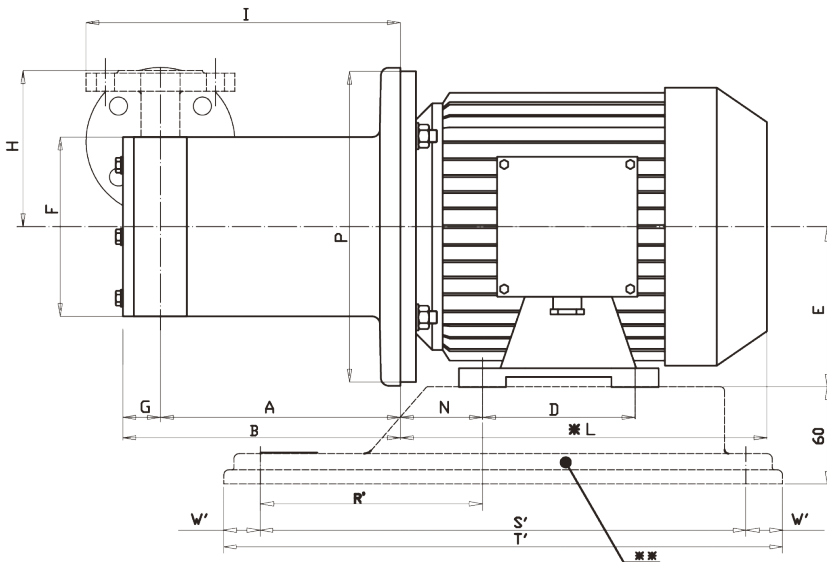

DIMENSIONS - mm -

PUMP TYPE	MOTOR FLANGE B3-B5		DIMENSIONS - mm -														BASEPLATE DIMENSIONS - mm -								
	SIZE	kW	A	B	C	D	E	F	G	H	I	*L	M	N	O	P	Q	U	R'	S'	T'	U'	V'	W'	Z'
HTA 25	802B	11	167	192	125	100	80	123	25	100	218	232	98	50	3/4" FEMALE	200	3/4" FEMALE	61	120	302	350	157	205	24	24
HTA 37	802B 90L2	11 22	167 177	192 202	125 140	100 125	80 90	123	25	100	220 230	232 280	98	50 56	3/4" FEMALE	200	3/4" FEMALE	61	120 132	302	350	157	205	24	24

FLANGES DIMENSIONS - mm -

PUMP TYPE	R	S	T	DNs	DNd	
HTA 25-37	75	105	14	20	20	DN20 PN40

* Different according to the motor supplier. ** OPTIONAL UPON REQUEST: DIN or ANSI Flanges and Baseplates. NOTE: DIRECTION OF ROTATION IS COUNTER CLOCKWISE AS SEEN WHEN FACING THE MOTOR. PUMPS AVAILABLE THREADED OR FLANGED.



HTA 49-78 SS / EM-T 49-78 SS (ATEX VERSION)

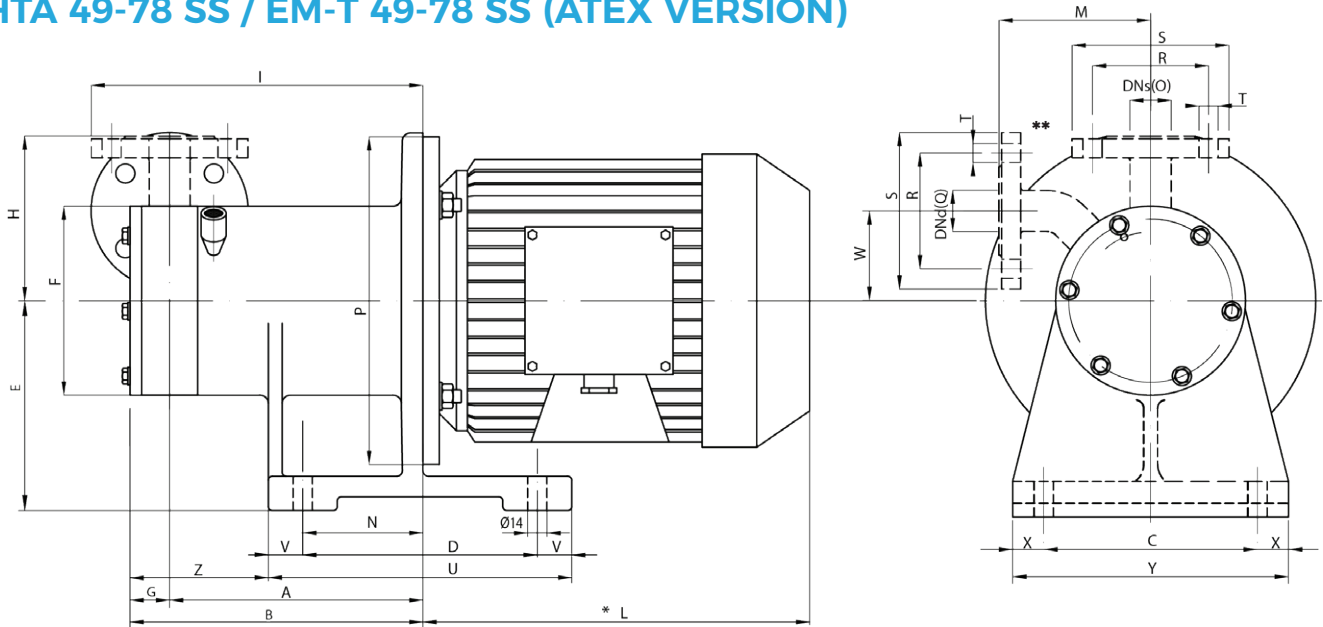

DIMENSIONS - mm -

PUMP TYPE	MOTOR B5		DIMENSIONS - mm -																				
	SIZE	kW	A	B	C	D	E	F	G	H	I	*L	M	N	O	P	Q	U	V	W	X	Y	Z
HTA 49	90 L2	22	185	215	155	170	150	139	30	121	253	280	111	109	1"	200	1"	220	25	62.5	22.5	200	91
	100 L2	3	205	235							263	316		119	FEMALE	250	FEMALE						
HTA 78	100 L2	3	205	235	155	170	150	158	30	133	263	316	133	119	1"	250	1"	220	25	85.5	22.5	200	91
	112 M2	4									324			FEMALE		FEMALE							

FLANGES DIMENSIONS - mm -

PUMP TYPE	R	S	T	DNs	DNd	
HTA 49-78	85	115	14	25	25	DN25 PN40

* Different according to the motor supplier. ** OPTIONAL UPON REQUEST: DIN or ANSI Flanges.
NOTE: DIRECTION OF ROTATION IS COUNTER CLOCKWISE AS SEEN WHEN FACING THE MOTOR.
PUMPS AVAILABLE THREADED OR FLANGED.



MAG-DRIVE ROTARY VANE PUMPS

SEAL-LESS MAG DRIVE VANE PUMPS

In seal-less magnetic drive vane pumps, the external magnet is directly connected to the motor shaft and it transmits the torque to the internal magnet. The magnetic field created produces a rotation without physical contact between the parts and the rotor spins. The vanes inside the rotor slide in and out of their seat and they move the fluid. The rear casing is placed between the two magnet joints and it hermetically closes the hydraulic part from the motor.

GemmeCotti supplies two different models of volumetric pumps:

HPP/HPF PP/PVDF

- Thermoplastic pumps made of PP or PVDF.
- Capacity up to 980 L/h.
- Pressure up to 5 bar.

HTP AISI 316

- Metallic pumps made of stainless steel AISI 316.
- Capacity up to 2100 L/h.
- Pressure up to 13 bar.
- Dry self-priming.

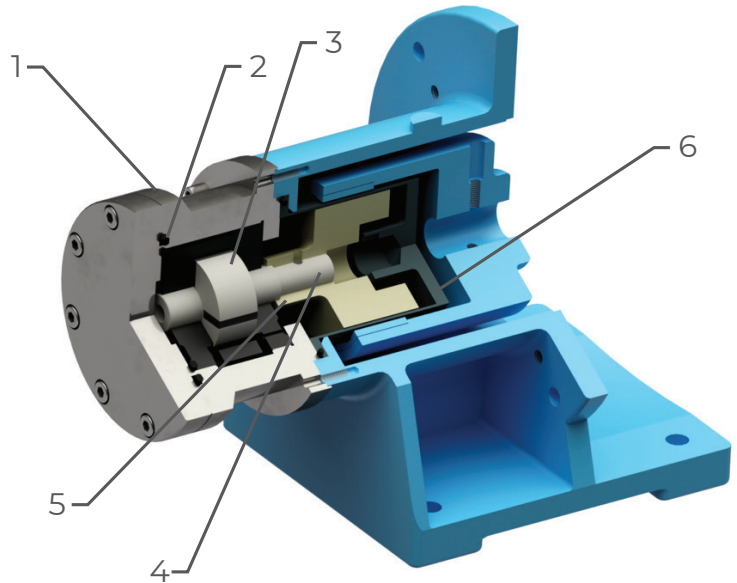

MATERIALS IN CONTACT WITH THE LIQUID		
PART NUMBER - DESCRIPTION	VANE PUMPS	
	HPP / HPF	HTP
1 - PUMP BODY + COVER	PP or PVDF	AISI 316
2 - O-RING	EPDM or VITON	EPDM or VITON
3 - FLANGES STATOR VANES + PINS	PVDF + GRAPHITE	GRAPHITE
4 - ROTOR SHAFT	PVDF	AISI 316
5 - INTERNAL MAGNET	PP or PVDF + NdFeB	AISI 316 + SmCo
6 - REAR CASING	PP or PVDF	AISI 316



THERMOPLASTIC MAG-DRIVE ROTARY VANE PUMPS



STANDARD

- High torque magnetic coupling.
- Direct starting motors.

OPTIONAL

- Flanges available (DIN or ANSI).
- Dry-running protection device.
- Baseplate.
- Available in ATEX version for zone 2 II 3G (pump mod. EM-P PP/PVDF).

Mag drive rotary vane pumps series **HPP-HPF** are made of thermoplastic materials (PP/PVDF) and are suitable for corrosive liquids, alkalis, toxic, noxious and carcinogenic fluids. Thanks to the **innovative mag drive system**, pumps model HPP-HPF reduce the risks of leakage and the maintenance costs. HPP-HPF pumps are **useful for low flow and high head applications** such as Pilot Plants and Sampling.

MAIN FEATURES

- **Materials available:** PP / PVDF.
- **Materials in contact with the liquid:** casing, end cover, internal magnet and rear casing: PP/PVDF; o-ring: EPDM (standard for PP pumps); VITON (standard for PVDF pumps); Graphite Stator; Rotor shaft: PVDF.
- **Max flow:** 980 L/h; **Max pressure** 5 bar.
- **Temperature:** PP: max 70°C - PVDF: max 90°C.
- **System pressure:** NP 5 bar at 20°C.

PERFORMANCE CURVES 50Hz - 1450 RPM

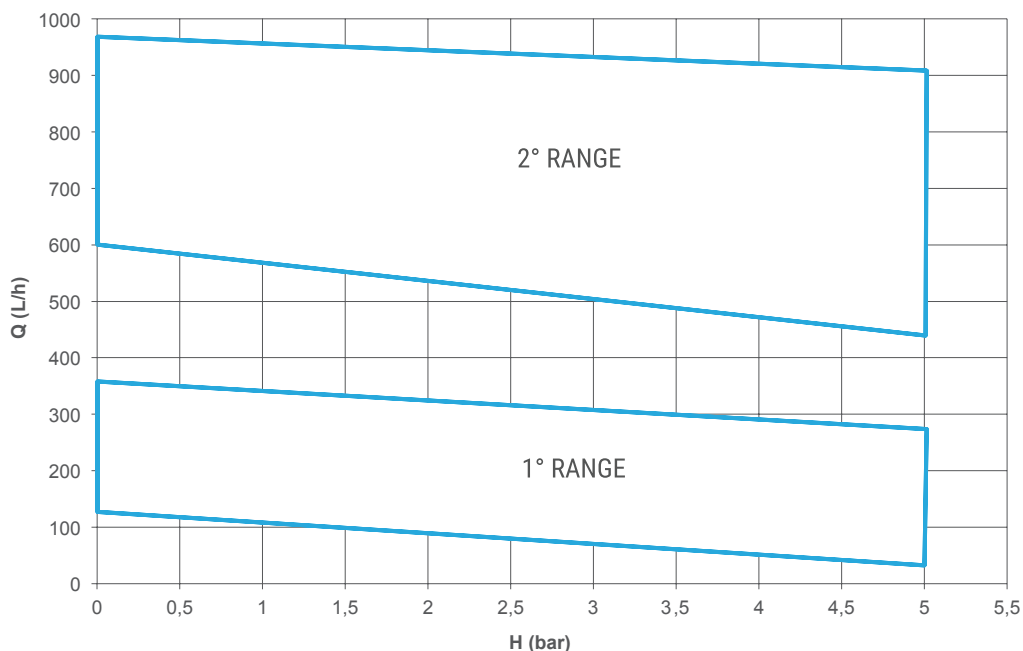

HPP/HPF TECHNICAL DATA

PUMP SIZE	MATERIAL	Q MAX		H MAX		SUCTION CONNECTION	DISCHARGE CONNECTION	PUMP WEIGHT (kg)		SUITABLE MOTOR POWER (kW) 1450 rpm	MOTOR FLANGE AND FRAME
		50Hz (L/h)	60Hz (USGPM)	50Hz (bar)	60Hz (PSI)			PP	PVDF		
HPP/HPF 100 1°R	PP- PVDF	120	0.66	5	72	3/8" FEMALE	3/8" FEMALE	2.9	3.2	0.37	71 - B3 / B5
HPP/HPF 200 1°R	PP- PVDF	200	1.1	5	72	3/8" FEMALE	3/8" FEMALE	2.9	3.2	0.37	71 - B3 / B5
HPP/HPF 300 1°R	PP- PVDF	290	1.5	5	72	3/8" FEMALE	3/8" FEMALE	2.9	3.2	0.37	71 - B3 / B5
HPP/HPF 400 1°R	PP- PVDF	360	1.8	5	72	3/8" FEMALE	3/8" FEMALE	2.9	3.2	0.37	71 - B3 / B5
HPP/HPF 600 2°R	PP- PVDF	600	2.5	5	72	1/2" FEMALE	1/2" FEMALE	7	7.5	1.5	90 - B3 / B5
HPP/HPF 800 2°R	PP- PVDF	800	3	5	72	1/2" FEMALE	1/2" FEMALE	7	7.5	1.5	90 - B3 / B5
HPP/HPF 1000 2°R	PP- PVDF	980	3.5	5	72	1/2" FEMALE	1/2" FEMALE	7	7.5	1.5	90 - B3 / B5

HPP-HPF 1° RANGE

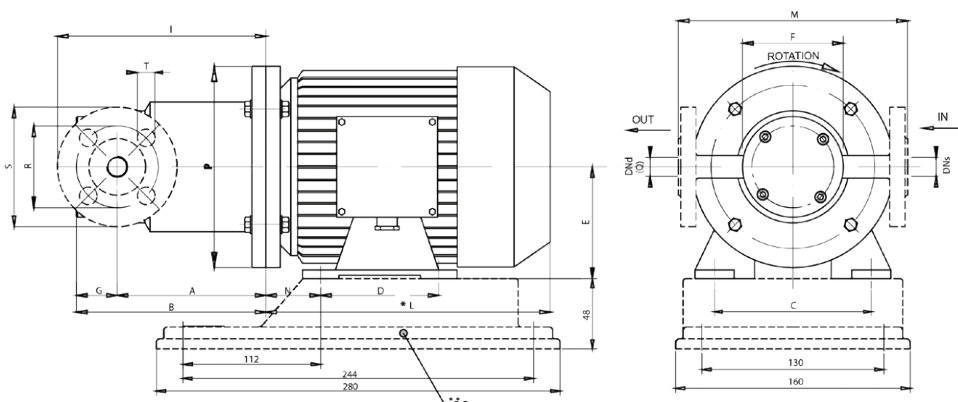

HPP-HPF 2° RANGE

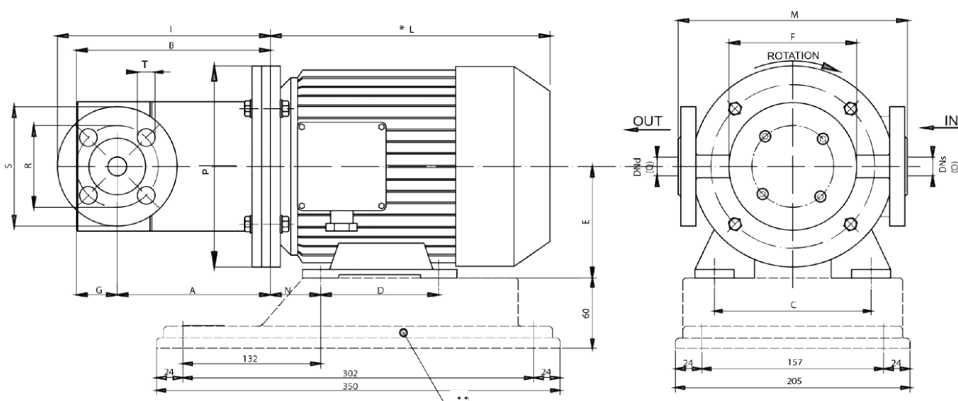

DIMENSIONS - mm -

PUMP TYPE	MOTOR FLANGE B3 - B5	kW	DIMENSIONS - mm -													FLANGES DIMENSIONS - mm -						
			A	B	C	D	E	F	G	I	*L	M	N	O	P	Q	R	S	T	DNs	Dnd	
HPP-HPF1° RANGE	714B	0.37	128	164	112	90	71	90	36	176	215	182	45	3/8" FEMALE	160	3/8" FEMALE	65	95	14	15	15	DN15 PN16
HPP-HPF2° RANGE	90S2	1.1 1.5	179	223	140	100	90	127	44	232	255	218	56	1/2" FEMALE	200	1/2" FEMALE	75	105	14	20	20	DN20 PN16

* Different according to the manufacturer. ** OPTIONAL UPON REQUEST: DIN or ANSI Flanges and Baseplates.



HTP AISI 316

METALLIC MAG-DRIVE ROTARY VANE PUMPS DRY SELF-PRIMING



Rotary vane mag drive pumps series **HTP** are made of **AISI 316** and are suitable for hydrocarbons, solvents, heat transfer oils, refrigerants, cryogenics and radioactive liquids. Thanks to the **innovative mag drive system**, pumps model HTP reduce the risks of leakage and emissions and the maintenance costs. HTP pumps are **useful for low flow and high head applications** such as Pilot Plants, Sampling and Flushing of mechanical seals. Especially designed for thin non-lubricating liquids and/or high differential pressure. Pumps series HTP are also available in **ATEX version for zone 1 and 2** (pump model EM-P AISI 316).

STANDARD

- High torque magnetic coupling.
- Direct starting motor.

OPTIONAL

- Flanges available (DIN or ANSI).
- Dry-running protection device.
- Baseplate.
- Explosion proof motor.
- Available in ATEX version for zone 1 II2G and zone 2 II 3G (pump mod. EM-P AISI 316).

MAIN FEATURES

- **Materials available:** AISI 316.
- **Materials in contact with the liquid:** pump body, end cover and rotor: AISI 316; o-ring: EPDM/VITON; carbon graphite stator.
- **Max flow:** 2100 L/h; **Max head** 13 bar.
- **Temperature range:** from - 70°C to + 200°C
- **Max viscosity:** 2000 cPs.
- **System pressure:** 25 bar at 20°C.
- Standard motor 4 poles

PERFORMANCE CURVES 50Hz - 1450 RPM

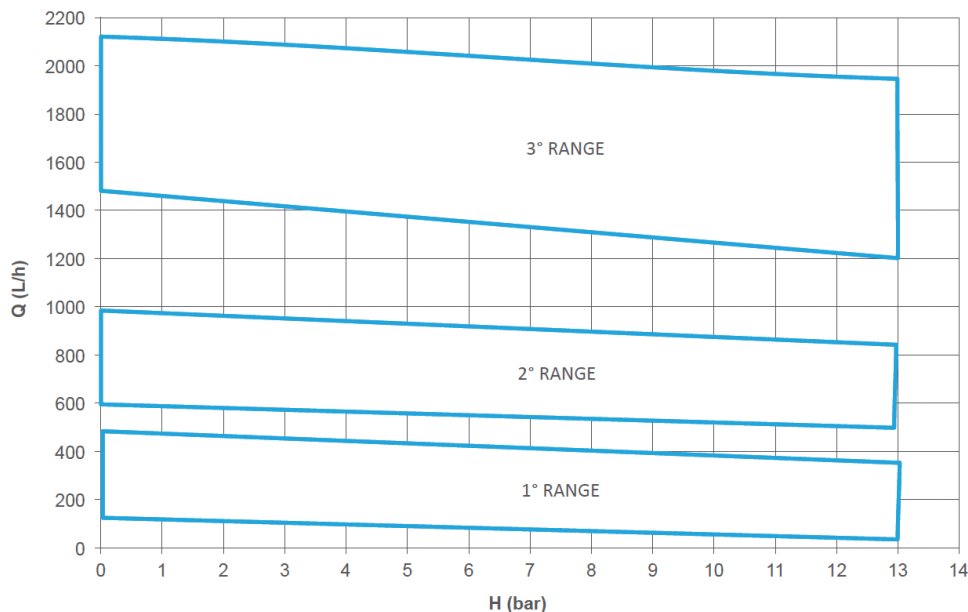

HTP TECHNICAL DATA

PUMP SIZE	MATERIAL	Q MAX		H MAX		SUCTION CONNECTION	DISCHARGE CONNECTION	PUMP WEIGHT (kg)	SUITABLE MOTOR POWER (kW) 1450 rpm - 4 POLES	MOTOR FLANGE AND FRAME
		50Hz (L/h)	60Hz (USGPM)	50Hz (bar)	60Hz (PSI)					
HTP 100 1R	AISI 316	120	0.66	13	188	3/8" FEMALE	3/8" FEMALE	3.4	0.37	71 - B3 / B5
HTP 200 1R	AISI 316	250	1.4	13	188	3/8" FEMALE	3/8" FEMALE	3.4	0.37	71 - B3 / B5
HTP 300 1R	AISI 316	350	1.9	13	188	3/8" FEMALE	3/8" FEMALE	3.4	0.37	71 - B3 / B5
HTP 400 1R	AISI 316	450	2.3	13	188	3/8" FEMALE	3/8" FEMALE	3.4	0.37	71 - B3 / B5
HTP 600 2R	AISI 316	600	3.3	13	188	1/2" FEMALE	1/2" FEMALE	8.1	0.75	80 - B3 / B5
HTP 800 2R	AISI 316	800	4.3	13	188	1/2" FEMALE	1/2" FEMALE	8.1	0.75	80 - B3 / B5
HTP 1000 2R	AISI 316	980	5	13	188	1/2" FEMALE	1/2" FEMALE	8.1	1.5	90 - B3 / B5
HTP 1500 3R	AISI 316	1500	8	13	188	3/4" FEMALE	3/4" FEMALE	22.6	1.5	90 - B5
HTP 2000 3R	AISI 316	2100	11.1	13	188	3/4" FEMALE	3/4" FEMALE	22.6	2.2 3 4	100 - B5 100 - B5 112 - B5

HTP 1°-2° RANGE / EM-P 1° - 2° RANGE (ATEX VERSION)

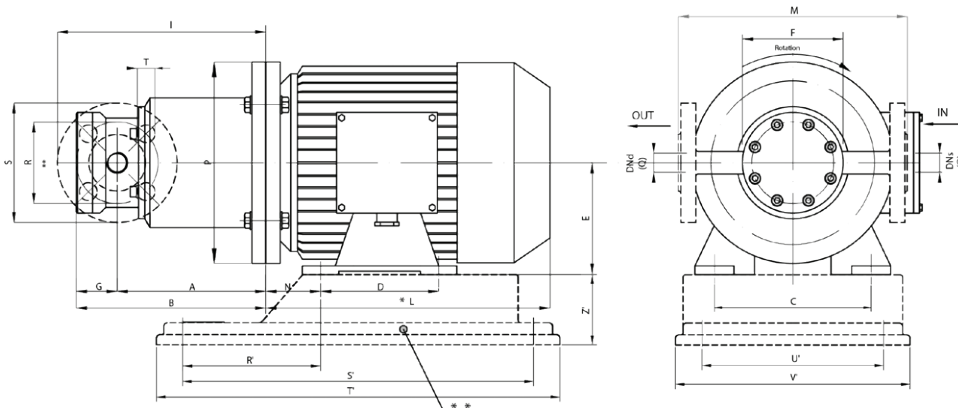

DIMENSIONS - mm -

PUMP TYPE	MOTOR FLANGES B3-B5		DIMENSIONS - mm -														BASEPLATE DIMENSIONS - mm -					
	SIZE	kW	A	B	C	D	E	F	G	I	*L	M	N	O	P	Q	R'	S'	T'	U'	V'	Z'
HTP 1° RANGE	714B	0.37	127	160	112	90	71	80	33	175	215	182	45	3/8" FEMALE	160	3/8" FEMALE	112	244	280	130	160	48
HTP 2° RANGE	804B 90L4	0.75 1.5	166 176	204 214	125 140	100 125	80 90	123	38	218	232 280	194	50 56	1/2" FEMALE	200	1/2" FEMALE	120 132	302	350	157	205	60

FLANGES DIMENSIONS - mm -

PUMP TYPE	R	S	T	DNs	DNd	
HTP 1° RANGE	65	95	14	15	15	DN15 PN40
HTP 2° RANGE	75	105	14	20	20	DN20 PN40

* Different according to the motor supplier.
 ** OPTIONAL UPON REQUEST: DIN or ANSI Flanges and Baseplates.
 NOTE: DIRECTION OF ROTATION IS COUNTER CLOCKWISE AS SEEN WHEN FACING THE MOTOR. PUMPS AVAILABLE THREADED OR FLANGED.



HTP AISI 316

METALLIC MAG-DRIVE ROTARY VANE PUMPS DRY SELF-PRIMING



HTP 3° RANGE / EM-P 3° RANGE (ATEX VERSION)

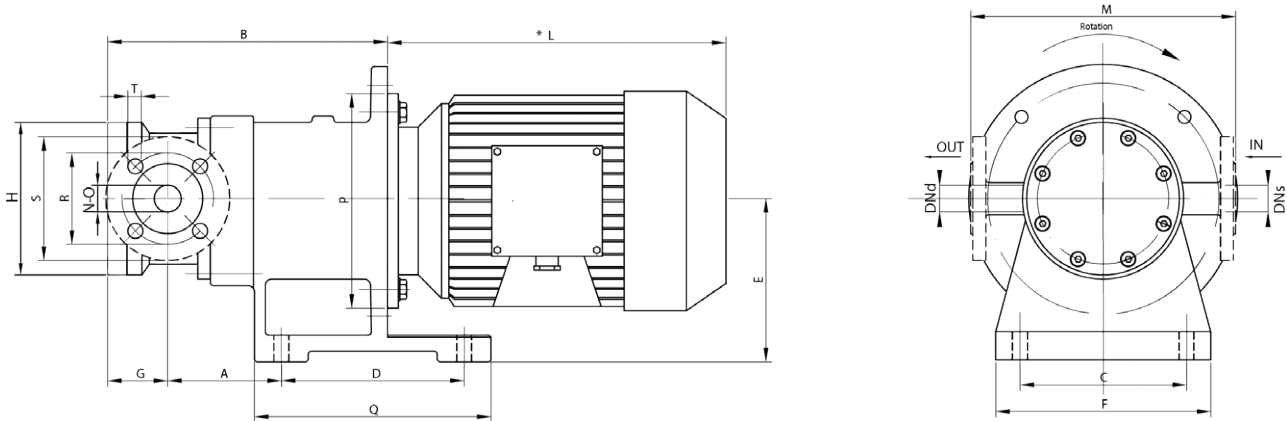

DIMENSIONS - mm -

PUMP TYPE	MOTOR FLANGE B5		DIMENSIONS - mm -													
	SIZE	kW	A	B	C	D	E	F	G	H	*L	M	N	O	P	Q
HTP 3° RANGE	90L	1.5	106	260	155	170	150	200	56	142	280	246	3/4" FEMALE	3/4" FEMALE	200	220
	100L	2.2/3	106	280	155	170	150	200	56	142	316	246	3/4" FEMALE	3/4" FEMALE	250	220
	112M	4	106	280	155	170	150	200	56	142	334	246	3/4" FEMALE	3/4" FEMALE	250	220

* Different according to the motor supplier. ** OPTIONAL UPON REQUEST: DIN or ANSI Flanges.
NOTE: DIRECTION OF ROTATION IS COUNTER CLOCKWISE AS SEEN WHEN FACING THE MOTOR.
PUMPS AVAILABLE THREADED OR FLANGED.

FLANGES DIMENSIONS - mm -

PUMP TYPE	R	S	T	DNs	DNd	
HTP 3° RANGE	85	115	14	25	25	DN25 PN40



MECHANICAL SEAL CENTRIFUGAL PUMPS

MECHANICAL SEAL CENTRIFUGAL PUMPS

Mechanical seal centrifugal pumps are the right solution for applications involving solids in the liquid because their design with open impeller allows to pump dirty liquids and fluids.

The seal in mechanical seal pumps is composed by a static ring and a rotating ring placed on the pump shaft which is directly coupled to the motor shaft. The two surfaces sliding together need to be lubricated and the seal lubricant is the liquid itself that is being pumped.

GemmeCotti supplies the following model of mechanical seal pump:

HCO PP/PVDF

- Thermoplastic pumps made of PP or PVDF.
- Capacity up to 130 m³/h.
- Head up to 48 mlc.

■ **Three different kinds of mechanical seals** are available:

1. The seal of pumps HCO size 95-10 is guaranteed by a **special elastomeric lip seal**.
2. HCO pumps from size 110 to 170 are equipped with an **Internal PTFE bellows mechanical seal** (sic/ceramic), which is manufactured by GemmeCotti.
3. HCO 180-200 are equipped with a **single or double mechanical seal back to back**.

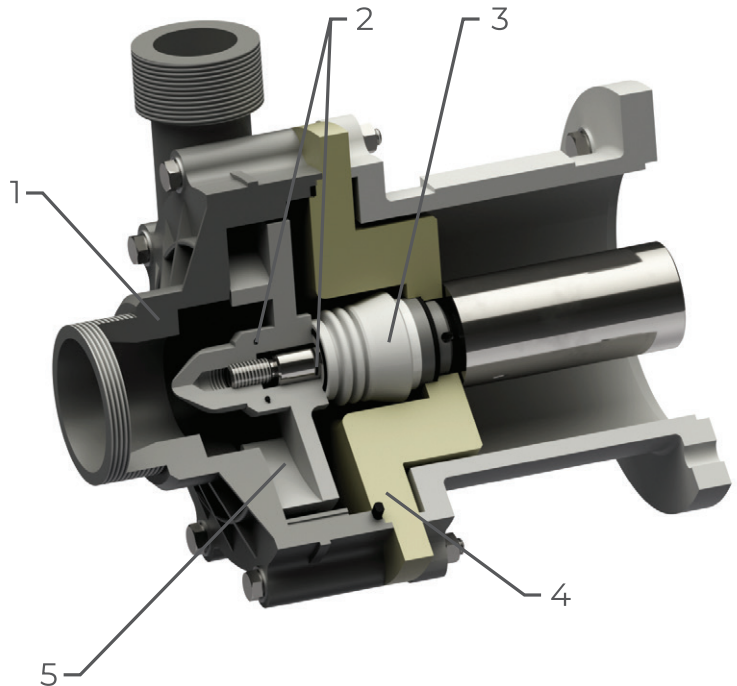

PART NUMBER - DESCRIPTION	MATERIALS IN CONTACT WITH THE LIQUID
	MECHANICAL SEAL PUMPS
1 - PUMP HEAD	HCO PP or PVDF
2 - O-RING	EPDM or VITON
3 - MECHANICAL SEAL	SiC + Al ₂ O ₃ or Graphite + Al ₂ O ₃
4 - COVER	PP or PVDF
5 - IMPELLER + IMPELLER NUT	PP or PVDF

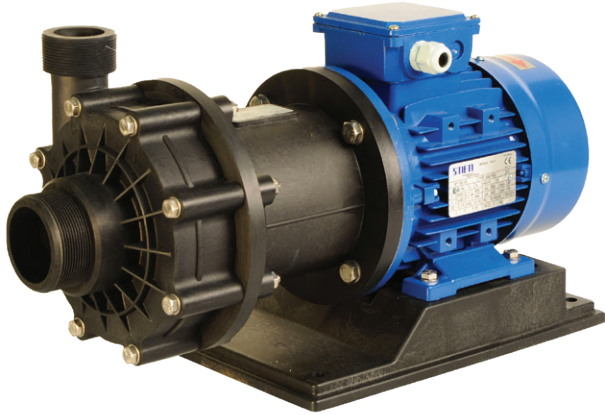

Centrifugal pumps series HCO with mechanical seal are made of thermoplastic materials (**Polypropylene** and **PVDF**) and are suitable for **highly corrosive liquids containing solids in suspension**. Three different kinds of mechanical seals are available:

1. The seal of pumps HCO size 95-10 is guaranteed by a **special elastomeric lip seal**.
2. HCO pumps from size 110 to 170 are equipped with an **internal PTFE bellows mechanical seal** (sic/ceramic), which is manufactured by GemmeCotti.
3. HCO 180-200 are equipped with a **single or double mechanical seal back to back**.

STANDARD

- BSP threaded in and out connections.
- Direct starting motor.

OPTIONAL

- Flanges available (DIN or ANSI).
- Dry-running protection device.
- Baseplate (from HCO 95 to HCO 140).
- Available in ATEX version for zone 2 II 3G (pump mod. EM-CO).

MAIN FEATURES

- **Materials available:** PP / PVDF.
- **Max flow:** 130 m³/h; **Max head:** 48 m.
- **Temperature:** PP: max 70°C - PVDF: max 90°C.
- **Max viscosity:** 200 cSt.
- **Pressure rating:** NP 6 at 20°C.
- Suitable for highly corrosive liquids containing solids in suspension (non-abrasive solids - max. 5% - dimension max. 3 mm).

PERFORMANCE CURVES 50Hz - 2900 RPM

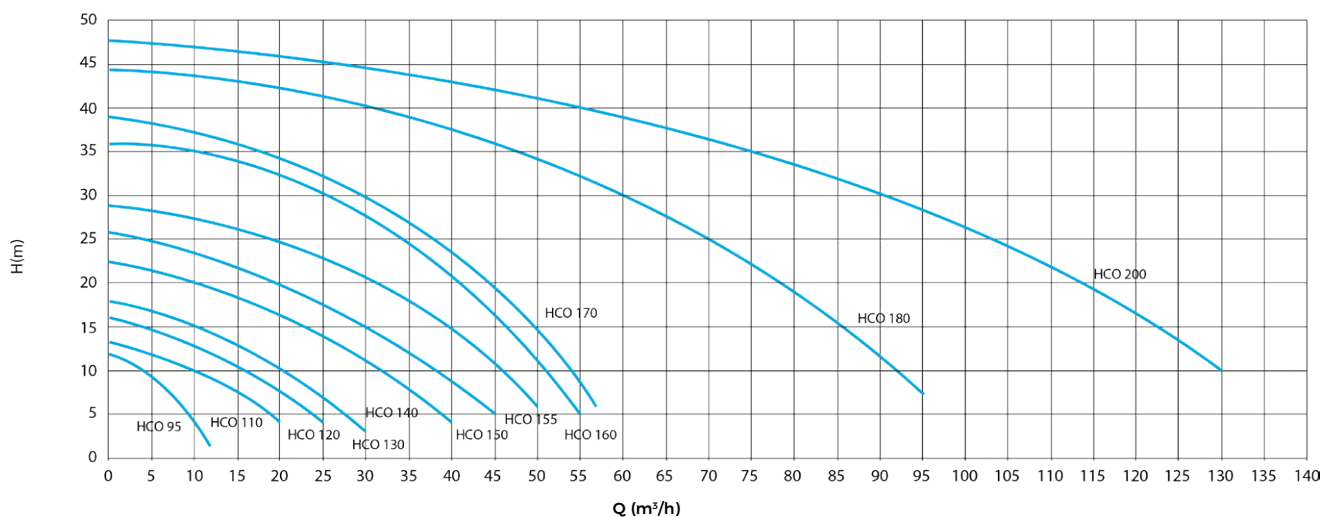

HCO TECHNICAL DATA

PUMP SIZE	MATERIAL	Q MAX		H MAX		SUCTION CONNECTION	DISCHARGE CONNECTION	PUMP WEIGHT (kg)		SUITABLE MOTOR POWER (kW) 2900 rpm	MOTOR FLANGE AND FRAME
		50Hz (m³/h)	60Hz (USCPM)	50Hz (m/c)	60Hz (ft)			PP	PVDF		
HCO 95-10	PP- PVDF	12	52	12	47	1" 1/2 FEMALE	1" MALE	10	12	0.55	71B - B3 / B5
HCO 110	PP- PVDF	20	88	13	59	2" 1/2 MALE	2" MALE	10	12	1.1	80B - B3 / B5
HCO 120	PP- PVDF	25	100	16	75	2" 1/2 MALE	2" MALE	10	12	1.5 - 2.2	90S - 90L - B3 / B5
HCO 130	PP- PVDF	30	158	18	90	2" 1/2 MALE	2" MALE	10	12	2.2	90L - B3 / B5
HCO 140	PP- PVDF	40	212	22	104	2" 1/2 MALE	2" MALE	11	13	3-4	100L - 112M - B3 / B5

HCO 95/10 - 110 - 120 - 130 - 140 PP/PVDF

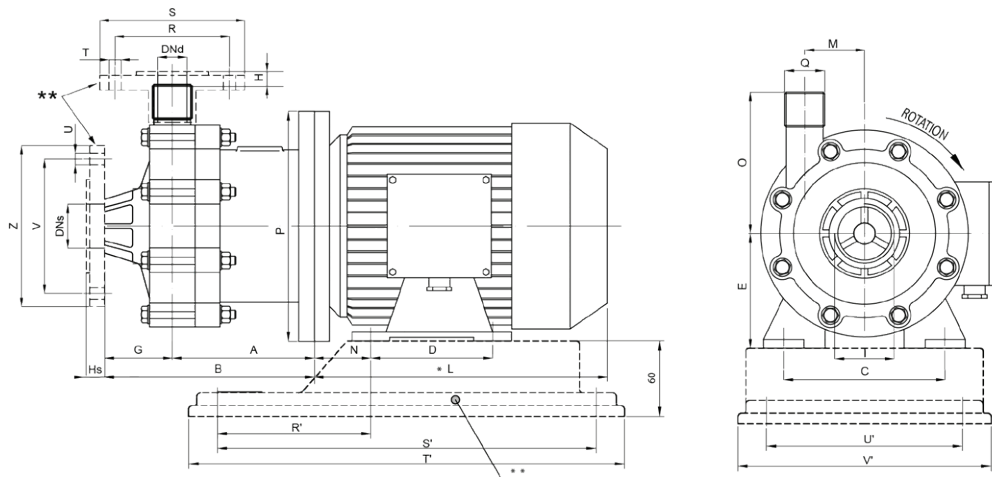

DIMENSIONS - mm -

PUMP TYPE	MOTOR FLANGE B3 - B5	kW	DIMENSIONS - mm -														
			A	B	C	D	E	G	Hs	H	I	*L	M	N	O	P	Q
HCO 95-10	71B	0.55	110	180	112	90	71	70	20	9	1" 1/2 FEMALE	215	45	45	100	160	1" MALE
HCO 110	80B	1.1	199	290	125	100	80	91	10	13	2" 1/2 MALE	232	66	50	140	200	2" MALE
HCO 120	90S	1.5	209	290	140	100	90	91	10	13	2" 1/2 MALE	262	66	56	140	200	2" MALE
	90L	2.2	209	290	140	125	90	91	10	13	2" 1/2 MALE	287	66	56	140	200	2" MALE
HCO 130	90L	2.2	209	290	140	125	90	91	10	13	2" 1/2 MALE	280	66	56	140	200	2" MALE
HCO 140	100L	3	219	310	160	140	100	91	10	13	2" 1/2 MALE	315	66	63	140	250	2" MALE
	112M	4	219	310	190	140	112	91	10	13	2" 1/2 MALE	325	66	70	140	250	2" MALE

FLANGES DIMENSIONS - mm -

PUMP TYPE	R	S	T	U	V	Z	DNs	DNd
HCO 95-10	85	115	14	18	110	150	40	25
HCO 110 - 120 - 130 - 140	125	168	18	18	145	188	65	50

BASEPLATE DIMENSIONS - mm -

PUMP TYPE	R'	S'	T'	U'	V'
HCO 95-10	112	244	280	130	160
HCO 110 - 120 - 130	120	302	350	157	205
HCO 140	140	352	400	202	250

* Different according to the motor supplier. ** OPTIONAL UPON REQUEST: DIN or ANSI Flanges and Baseplates (from HCO 95 to HCO 140).
NOTE: DIRECTION OF ROTATION IS COUNTER CLOCKWISE AS SEEN WHEN FACING THE MOTOR.
PUMPS AVAILABLE THREADED OR FLANGED.



HCO TECHNICAL DATA

PUMP SIZE	MATERIAL	Q MAX		H MAX		SUCTION CONNECTION	DISCHARGE CONNECTION	PUMP WEIGHT (kg)		SUITABLE MOTOR POWER (kW) 2900 rpm	MOTOR FLANGE AND FRAME
		50Hz (m³/h)	60Hz (USGPM)	50Hz (m/c)	60Hz (ft)			PP	PVDF		
HCO 150	PP- PVDF	45	242	26	124	3" MALE	2" 1/2 MALE	11	13	5.5 - 7.5 - 9.2	132 SA - 132 SB - 132 MA - B3/B5
HCO 155	PP- PVDF	50	265	29	140	3" MALE	2" 1/2 MALE	11	13	5.5 - 7.5 - 9.2	132 SA - 132 SB - 132 MA - B3/B5
HCO 160	PP- PVDF	55	290	36	170	3" MALE	2" 1/2 MALE	11	13	7.5 - 9.2	132 SB - 132 MA - B3/B5
HCO 170	PP- PVDF	58	300	38	175	3" MALE	2" 1/2 MALE	11	13	7.5 - 9.2	132 SB - 132 MA - B3/B5

HCO 150 - 155 - 160 - 170 PP/PVDF

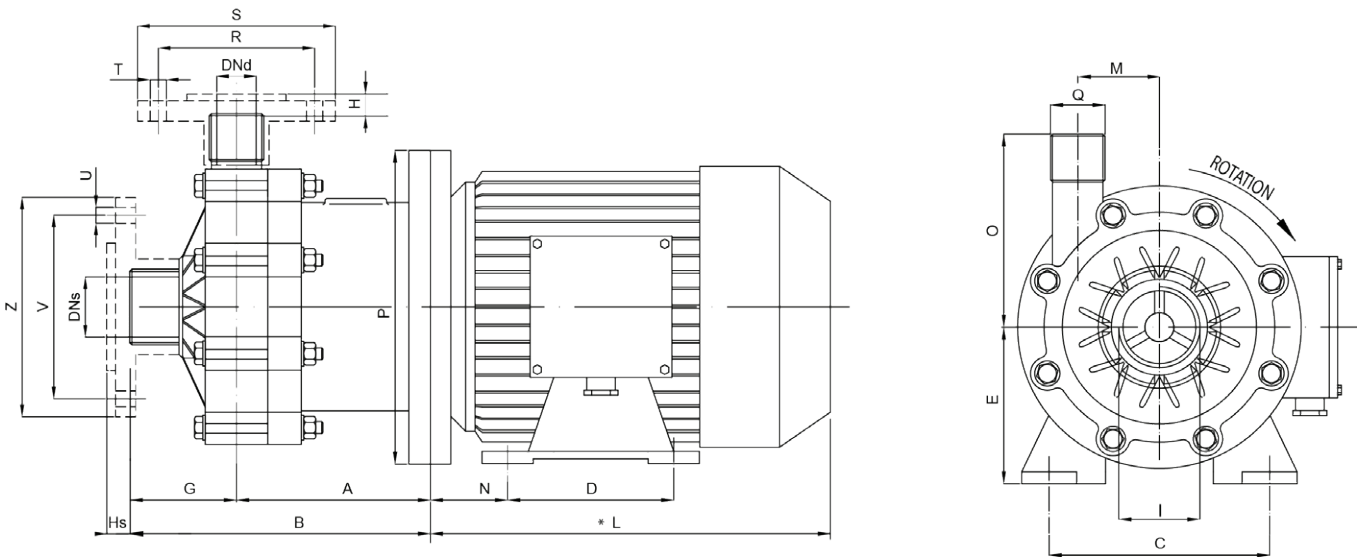

DIMENSIONS - mm -

PUMP TYPE	MOTOR FLANGE B3 - B5	kW	DIMENSIONS - mm -														
			A	B	C	D	E	G	Hs	H	I	*L	M	N	O	P	Q
HCO 150 - HCO155	132 SA-SB	5.5	184	275	216	140	132	91	10	10	3" MALE	380	82.5	89	170	300	2" 1/2 MALE
	132 SA-SB	7.5	184	275	216	140	132	91	10	10	3" MALE	380	82.5	89	170	300	2" 1/2 MALE
	132 MA	9.2	184	275	216	178	132	91	10	10	3" MALE	418	82.5	89	170	300	2" 1/2 MALE
HCO 160 - HCO170	132SB	7.5	184	275	216	140	132	91	10	10	3" MALE	380	82.5	89	170	300	2" 1/2 MALE
	132 MA	9.2	184	275	216	178	132	91	10	10	3" MALE	418	82.5	89	170	300	2" 1/2 MALE

* Different according to the motor supplier.
 ** OPTIONAL UPON REQUEST: DIN or ANSI Flanges.
 NOTE: DIRECTION OF ROTATION IS COUNTER CLOCKWISE AS SEEN WHEN FACING THE MOTOR.
 PUMPS AVAILABLE THREADED OR FLANGED.

FLANGES DIMENSIONS - mm -

PUMP TYPE	R	S	T	U	V	Z	DNs	DNd
HCO 150 - 155 - 160 - 170	145	188	18	18	160	203	80	65

HCO TECHNICAL DATA

PUMP SIZE	MATERIAL	Q MAX		H MAX		SUCTION CONNECTION	DISCHARGE CONNECTION	PUMP WEIGHT (kg)		SUITABLE MOTOR POWER (kW) 2900 rpm	MOTOR FLANGE AND FRAME
		50Hz (m³/h)	60Hz (USCPM)	50Hz (m/c)	60Hz (ft)			PP	PVDF		
HCO 180	PP- PVDF	95	502	44	208	3" 1/2 MALE	2" 1/2 MALE	13	15	11 - 15 - 18.5 - 22	160MA - 160MB - 160 L -180 M - B3/B5
HCO 200	PP- PVDF	130	687	48	227	4" MALE	3" 1/2 MALE	13	15	15 - 18.5 - 22 - 37	160MB - 160L - 180M 200LB - B3/B5

HCO 180 - 200 PP/PVDF

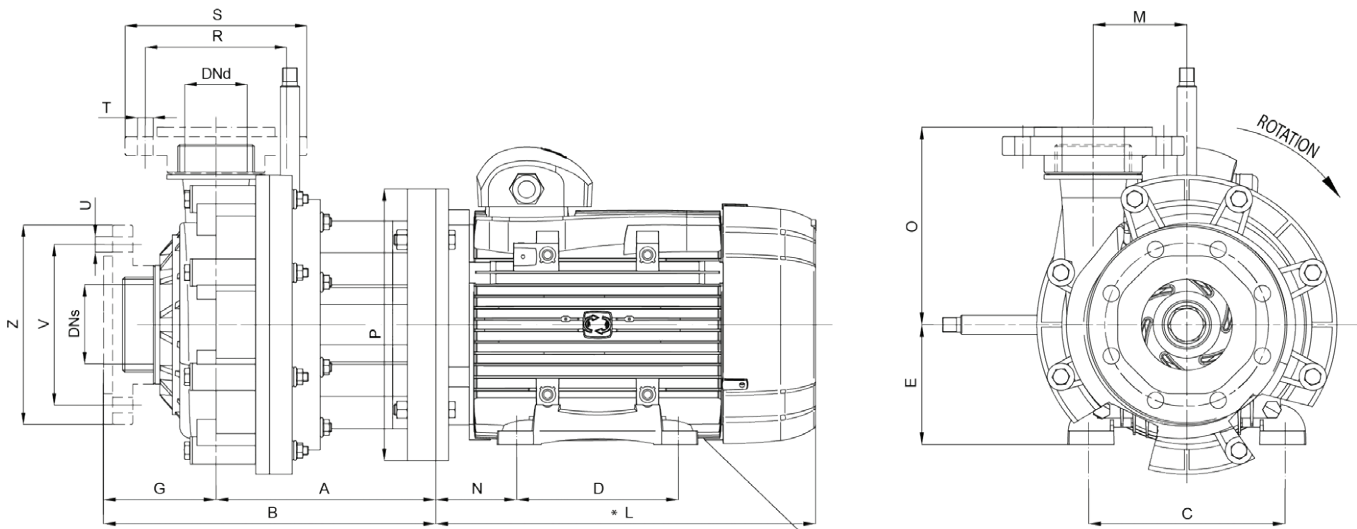

DIMENSIONS - mm -

PUMP TYPE	MOTOR FLANGE B3 - B5	kW	DIMENSIONS - mm -										
			A	B	C	D	E	G	*L	M	N	O	P
HCO180	160 MA	11	272	397	254	210	160	126	555	103	108	215.5	350
	160 MB	15	272	397	254	210	160	126	555	103	108	215.5	350
	160 L	18.5	272	397	254	254	160	126	575	103	108	215.5	350
	180 M	22	272	397	279	241	180	126	620	103	121	215.5	350
HCO 200	160 MB	15	272	395.5	254	210	160	125	555	103	108	218	350
	160 L	18.5	272	395.5	254	254	160	125	575	103	108	218	350
	180 M	22	272	395.5	279	241	180	125	620	103	121	218	350
	200 LB	37	272	395.5	318	305	200	125	675	103	133	218	400

FLANGES DIMENSIONS - mm -

PUMP TYPE	R	S	T	U	V	Z	DNs	DNd
HCO 180	145	185	18	18	160	200	80	65
HCO 200	160	200	18	18	180	220	100	80

* Different according to the motor supplier. ** OPTIONAL UPON REQUEST: DIN or ANSI Flanges.
NOTE: DIRECTION OF ROTATION IS COUNTER CLOCKWISE AS SEEN WHEN FACING THE MOTOR.
PUMPS AVAILABLE THREADED OR FLANGED.

VERTICAL PUMPS

VERTICAL CENTRIFUGAL PUMPS

Vertical centrifugal pumps are suitable for installations with the pump immersed directly in the tank.

GemmeCotti supplies the following models of vertical pumps:

HV PP/PVDF

- Thermoplastic pumps made of PP or PVDF.
- Capacity up to 40 m³/h.
- Head up to 22 m.
- Monobloc pump with semi open-impeller.
- Suitable for highly corrosive liquids with solids in suspension.
- Column length up to 1000 mm.

HVL PP/PVDF

- Thermoplastic pumps made of PP or PVDF.
- Capacity up to 130 m³/h.
- Head up to 48 m.
- Centrifugal pump with coupling and semi open-impeller.
- Suitable for highly corrosive liquids with solids in suspension.
- Column length up to 2000 mm.

HTM-V PP/PVDF

- Vertical magnetic drive pumps.
- Thermoplastic pumps made of PP or PVDF.
- Capacity up to 23 m³/h.
- Head up to 20 m.
- Column length: 320 mm.

PVA AISI 316

- Vertical centrifugal cantilever pumps.
- Made of AISI 316.
- Capacity up to 24 m³/h.
- Head up to 26 m.
- Especially designed for the production of PCBs.

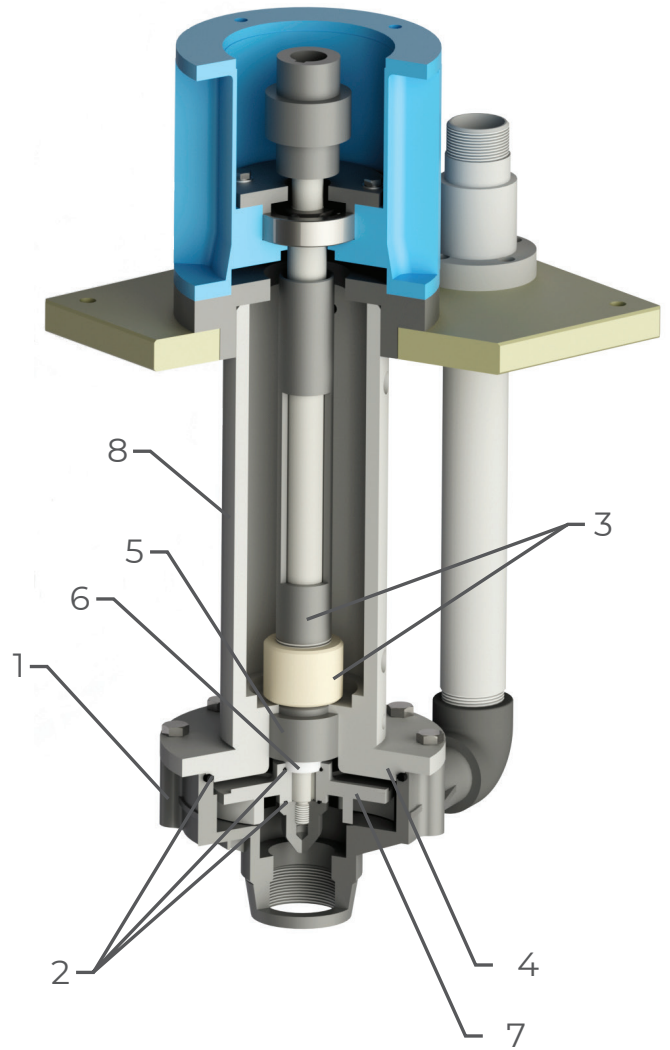

MATERIALS IN CONTACT WITH THE LIQUID		
PART NUMBER - DESCRIPTION	VERTICAL PUMPS	
	HV	HVL
1 - PUMP HEAD	PP or PVDF	PP or PVDF
2 - O-RING	EPDM or VITON	EPDM or VITON
3 - SHAFT COVERING/ GUIDE SHAFT COV.	PP	PP
4 - COVER	PP or PVDF	PP or PVDF
5 - BUSHING	PTFEC	PTFEC
6 - WEAR BUSHING	Al ₂ O ₃	Al ₂ O ₃
7 - IMPELLER	PP or PVDF	PP or PVDF
8 - COLUMN	PP or PVDF	PP or PVDF



MAIN FEATURES

- Centrifugal monobloc pump.
- **Materials available:** PP / PVDF.
- **Max flow:** 40 m³/h; **Max head:** 22 m.
- **Temperature:** PP: max 70°C; PVDF: max 90°C.
- Suitable for highly corrosive liquids containing solids in suspension.
- **Column length:** from 500 to 1000 mm.

STANDARD

- BSP threaded In and Out connections.

OPTIONAL

- Dry-running protection device.
- Flanges available.
- Suction strainer.

PERFORMANCE CURVES 50Hz - 2900 RPM

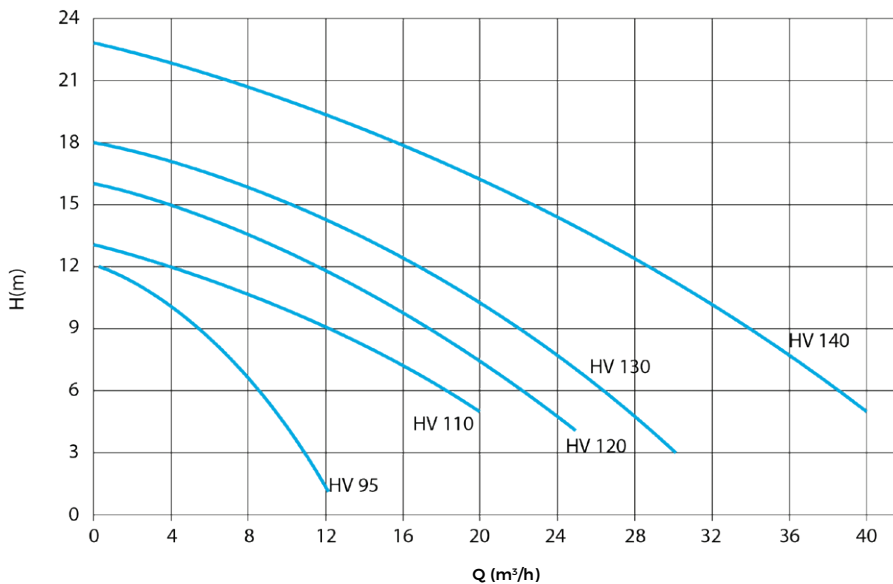

HV TECHNICAL DATA

PUMP SIZE	MATERIAL	Q MAX		H MAX		SUCTION CONNECTION	DISCHARGE CONNECTION	COLUMN LENGTHS (mm)	SUITABLE MOTOR POWER (kW) 2900 rpm	MOTOR FLANGE AND FRAME
		50Hz (m ³ /h)	60Hz (USGPM)	50Hz (m/c)	60Hz (ft)					
HV 95	PP- PVDF	12	62	12	55	2" FEMALE	1" 1/2 MALE	from 500 to 1000	0.75	80 2A - B5
HV 110	PP- PVDF	20	105	13	60	2" FEMALE	1" 1/2 MALE	from 500 to 1000	1.1	80 2B - B5
HV 120	PP- PVDF	25	132	16	75	2" FEMALE	1" 1/2 MALE	from 500 to 1000	1.5	90 S - B5
HV 130	PP- PVDF	30	158	18	90	2" FEMALE	1" 1/2 MALE	from 500 to 1000	2.2	90 L - B5
HV 140	PP- PVDF	40	210	22	105	2" FEMALE	1" 1/2 MALE	from 500 to 1000	3	100 L - B5

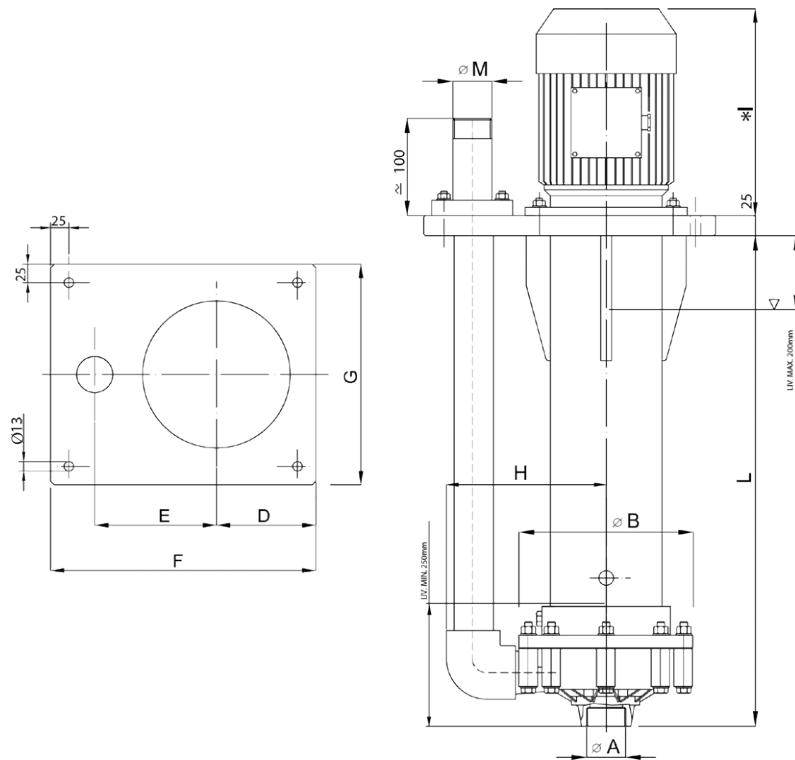
HV 95 - 110 - 120 - 130 - 140 PP/PVDF

DIMENSIONS - mm -

PUMP TYPE	MOTOR FLANGE B5	kW	DIMENSIONS - mm -									
			Ø A	Ø M	Ø B	D	E	F	G	H	I	L
HV 95	80 2A	0.75									215	
HV 110	80 2B	1.1									230	
HV 120	90 S	1.5	2" FEMALE	1" 1/2 MALE	215	135	165	360	300	196	255	Upon request from 500 to 1000 mm
HV 130	90 L	2.2									280	
HV 140	100 L	3									315	

* Different according to the motor supplier.



MAIN FEATURES

- Centrifugal pump with coupling.
- **Materials available:** PP/PVDF.
- **Max flow:** 130 m³/h; **Max head:** 48 m.
- **Temperature:** PP: max 70°C; - PVDF: max 90°C.
- Suitable for highly corrosive liquids containing solids in suspension.
- **Column length:** from 500 to 2000 mm.

STANDARD

- BSP threaded In and Out connections device.

OPTIONAL

- Dry-running protection device.
- Flanges available.
- Suction strainer.

PERFORMANCE CURVES 50Hz - 2900 RPM

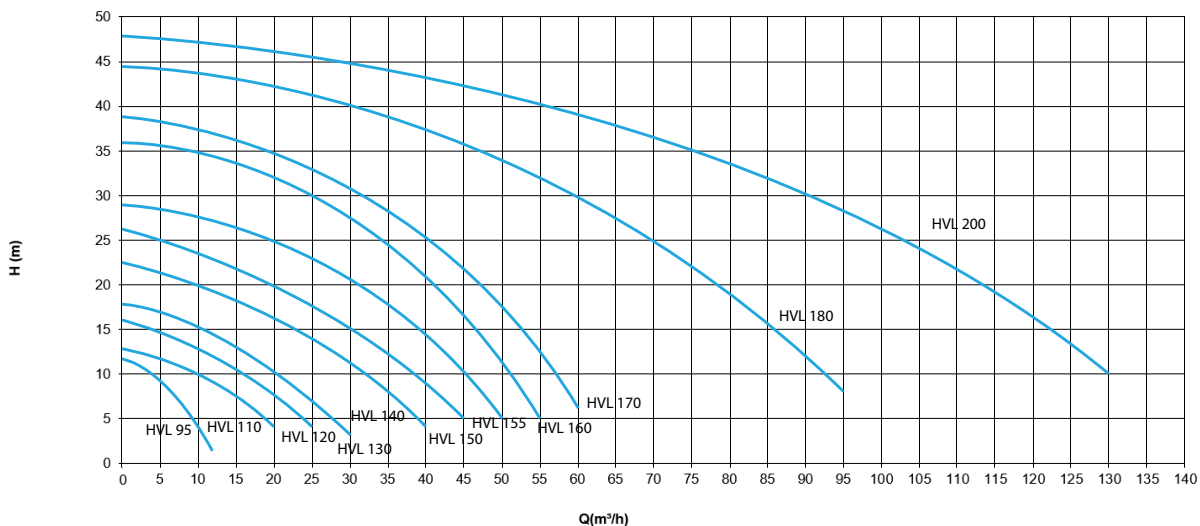



HVL TECHNICAL DATA

PUMP SIZE	MATERIAL	Q MAX		H MAX		SUCTION CONNECTION	DISCHARGE CONNECTION	COLUMN LENGTHS (mm)	SUITABLE MOTOR POWER (kW) 2900 rpm	MOTOR FLANGE AND FRAME
		50Hz (m³/h)	60Hz (USGPM)	50Hz (m/c)	60Hz (ft)					
HVL 95	PP- PVDF	12	62	12	55	2" FEMALE	1" 1/2 MALE	from 500 to 2000	0.75	80 2A - B5
HVL 110	PP- PVDF	20	105	13	60	2" FEMALE	1" 1/2 MALE	from 500 to 2000	1.1	80 2B - B5
HVL 120	PP- PVDF	25	132	16	75	2" FEMALE	1" 1/2 MALE	from 500 to 2000	1.5	90 S - B5
HVL 130	PP- PVDF	30	158	18	90	2" FEMALE	1" 1/2 MALE	from 500 to 2000	2.2	90 L - B5
HVL 140	PP- PVDF	40	210	22	105	2" FEMALE	1" 1/2 MALE	from 500 to 2000	3-4	100 L - 112 M - B5

HVL 95 - 110 - 120 - 130 - 140 PP/PVDF

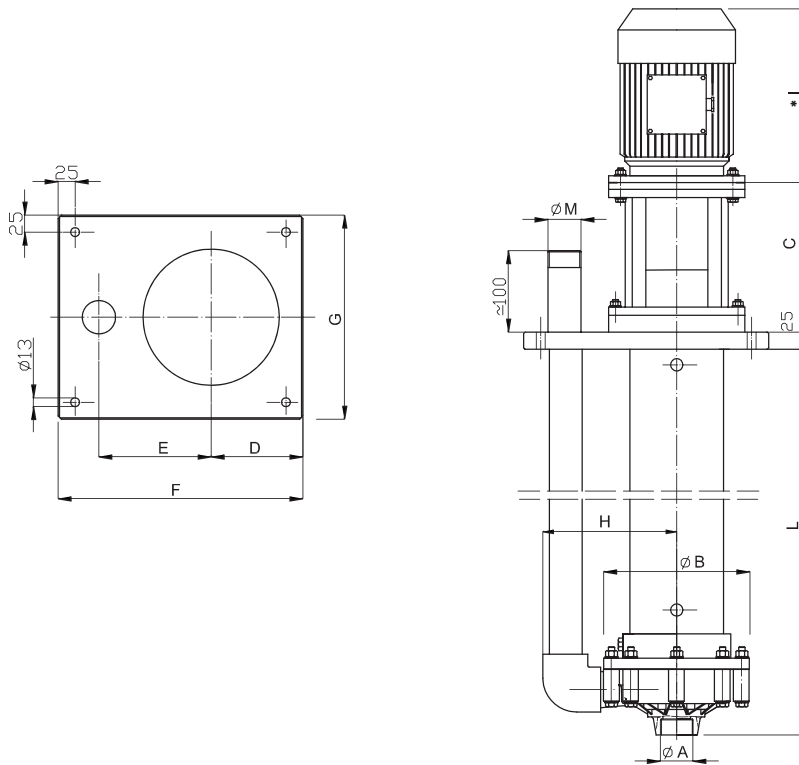

DIMENSIONS - mm -

PUMP TYPE	MOTOR FLANGE B5	kW	DIMENSIONS - mm -											
			ϕA	ϕM	ϕB	C	D	E	F	G	H	I	L	
HVL 95	802A	0.75				210							215	
HVL 110	802B	1.1				210							230	
HVL 120	90 S	1.5	2" FEMALE	1" 1/2 MALE	215	220	135	165	360	300	196		255	Upon request from 500 to 2000 mm
HVL 130	90 L	2.2				220							280	
HV 140	100L	3				230							315	
HV 140	112M	4				230							337	

* Different according to the motor supplier

HVL TECHNICAL DATA

PUMP SIZE	MATERIAL	Q MAX		H MAX		SUCTION CONNECTION	DISCHARGE CONNECTION	COLUMN LENGTHS (mm)	SUITABLE MOTOR POWER (kW) 2900 rpm	MOTOR FLANGE AND FRAME
		50Hz (m ³ /h)	60Hz (USCPM)	50Hz (m/c)	60Hz (ft)					
HVL 150	PP- PVDF	45	240	26	120	3" MALE	2" MALE	from 500 to 2000	5.5 - 7.5	132 S2A - 132 SB - B5
HVL 155	PP- PVDF	50	265	29	140	3" MALE	2" MALE	from 500 to 2000	5.5 - 7.5	132 S2A - 132 SB - B5
HVL 160	PP- PVDF	55	290	36	175	3" MALE	2" MALE	from 500 to 2000	7.5 - 9.2	132 SB - 132 MA - B5
HVL 170	PP- PVDF	57	300	39	180	3" MALE	2" MALE	from 500 to 2000	9	132 S - B5
HVL 180	PP- PVDF	95	502	44	208	4" MALE	3" 1/2 MALE	from 500 to 2000	11 - 22 - 37	160M - 180M - 200L - B5
HVL 200	PP- PVDF	130	687	48	227	4" MALE	3" 1/2 MALE	from 500 to 2000	11 - 22 - 37	160M - 180M - 200L - B5

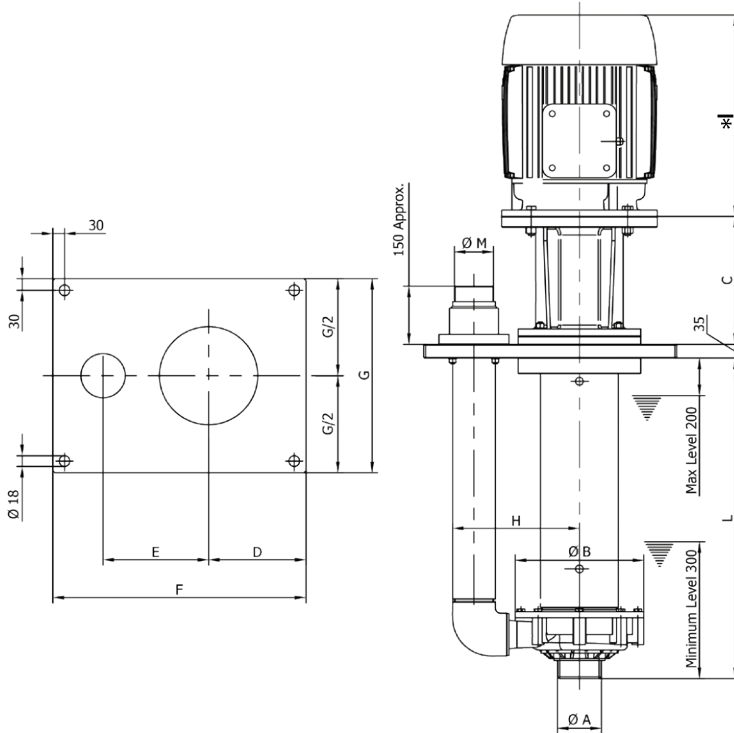
HVL 150 - 155 - 160 - 170 - 180 - 200 PP/PVDF

DIMENSIONS - mm -

PUMP TYPE	MOTOR FLANGE B5	kW	DIMENSIONS - mm -												
			Ø A	Ø M	Ø B	C	D	E	F	G	H	I	L		
HVL 150	132 SA 132 SB	5.5 7.5				265									
HVL 155	132 SA 132 SB	5.5 7.5											380		
HVL 160	132 SB 132 MA	7.5 9.2	3" MALE	2" MALE	275		170	215	480	380	260		380 418	Upon request from 500 to 2000 mm	
HVL 170	132 S	9				250							420		
HVL 180 - HVL 200	160 M 180 M 200 L	11 22 37	4" MALE	3" 1/2 MALE	330	330	250	271	650	500	325		531 645 760		

* Different according to the motor supplier



Vertical mag drive centrifugal pumps series HTM-V are made of thermoplastic materials (**Polypropylene** and **PVDF**) and are suitable to handle chemicals and corrosive liquids. This kind of pump has been designed for a vertical submerged installation, providing high reliability for intank and sump applications. HTM-V are **seal-less magnetic drive pumps** without any kind of labyrinth or mechanical seal. **The column of the pump is hermetically sealed** and it allows complete isolation of the motor, the extension shaft and external magnet of the pump from the process liquid.

MAIN FEATURES

- **Materials available:** PP / PVDF.
- **Materials in contact with the liquid:** casing and impeller: PP/PVDF; o-ring: EPDM (standard for PP pumps); VITON (standard for PVDF pumps); shaft: Al²O³ 99,7%; bushing: PTFEC.
- **Max flow:** 22 m³/h; **Max head** 20 m.
- **Temperature:** PP: max 70°C – PVDF: max 90°C.
- Compact design, **column length 320mm.**

OPTIONAL

- Dry running protection device.
- Also available with bracket suitable for NEMA motors.

PERFORMANCE CURVES 50Hz - 2900 RPM

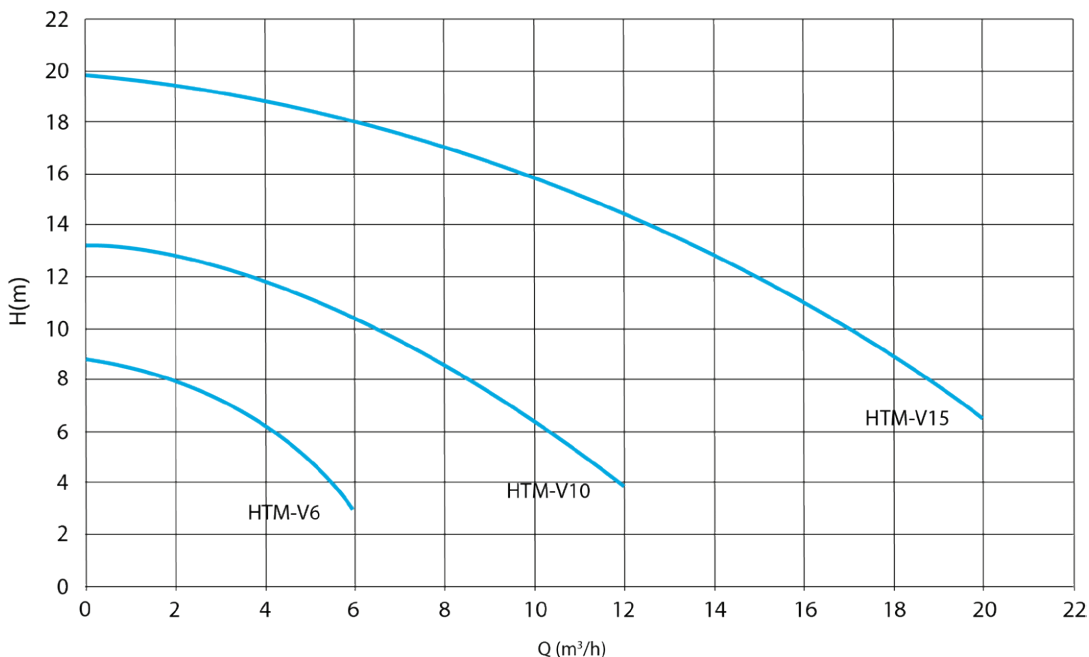



CENTRIFUGAL VERTICAL CANTILEVER PUMPS

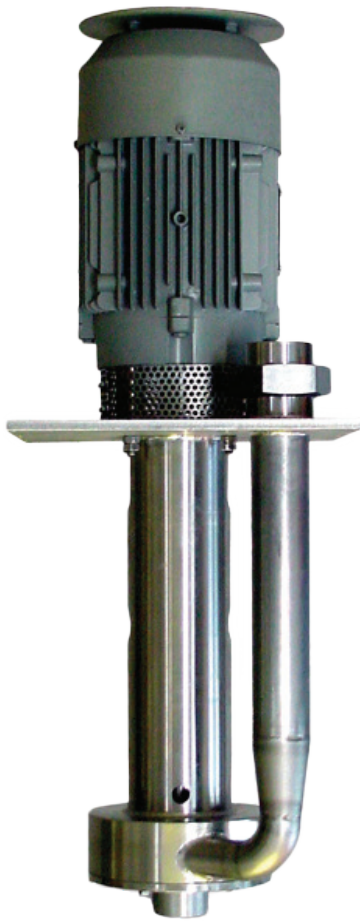

MAIN FEATURES

- **Materials available:** AISI 316.
- **Max flow:** 24 m³/h; **Max head:** 26 m.
- Fume labyrinth seal. A combined system of labyrinth, rings and PTFE lip seal guarantees tightness against gas and vapours.
- Impeller with low axial thrust.
- **Suitable for corrosive liquids containing solids.**
- Especially **designed for use in the production of printed circuit boards (PCB).**
AISI 316 version is suitable for potassium permanganate applications at 90°C.
- **Two different types available:** PVA 1 for tank transfer and PVA 2 used as a boosting pump. PVA 2 model should be installed in the same tank where PVA 1. This provides a tight system which prevents any leaks.

PERFORMANCE CURVES 50Hz - 2900 RPM

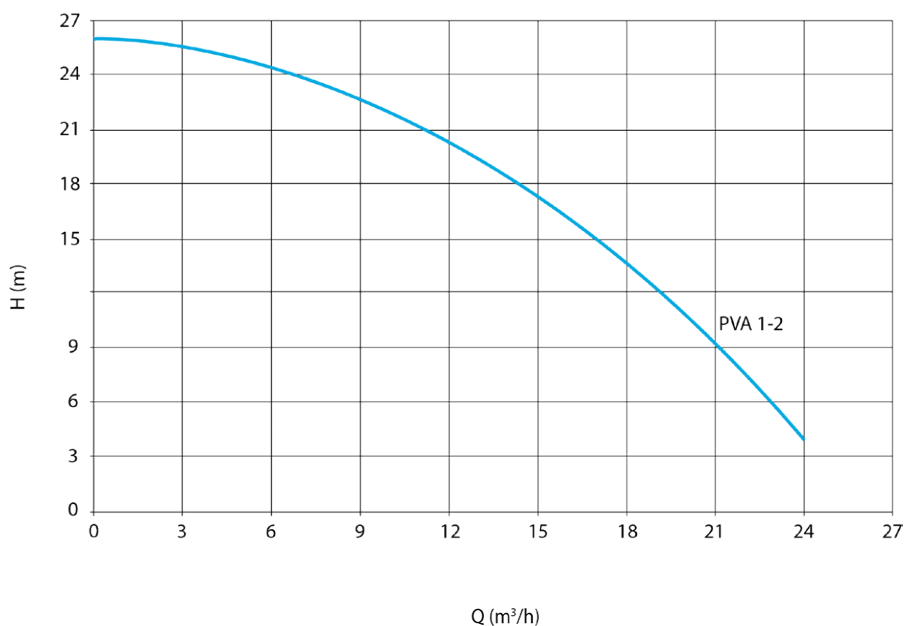



HAOD 20

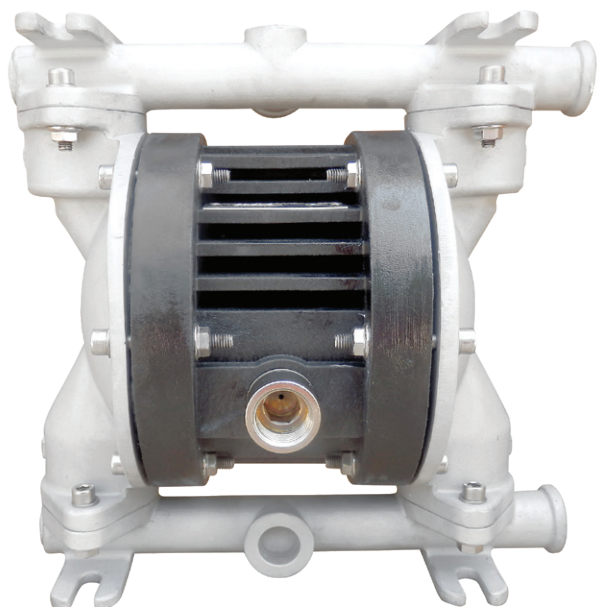

The **double diaphragm pumps HAOD** are suitable to pump aggressive liquids, even with very high viscosity and solids in suspension. These pumps are built with an anti-stalling pneumatic circuit that **ensures the highest possible level of security** and efficiency and it doesn't require lubricated air. The HAOD pumps are available in **several materials and dimensions** and they **can operate in potentially explosive atmospheres (ATEX version)**.

MAIN FEATURES

- **Materials available:** PP / PVDF / AISI 316.
- **Max operating temperature:** PP: 60°C - PVDF: 95°C - AISI 316: 95°C.
- Adjustable capacity and head.
- **Can function even if dry-running.**
- Automatic suction and potential to be submersible.
- Ecological design ensuring a reduction of air consumption.

OPTIONAL

- Pulsation dampeners.
- Available in ATEX version.

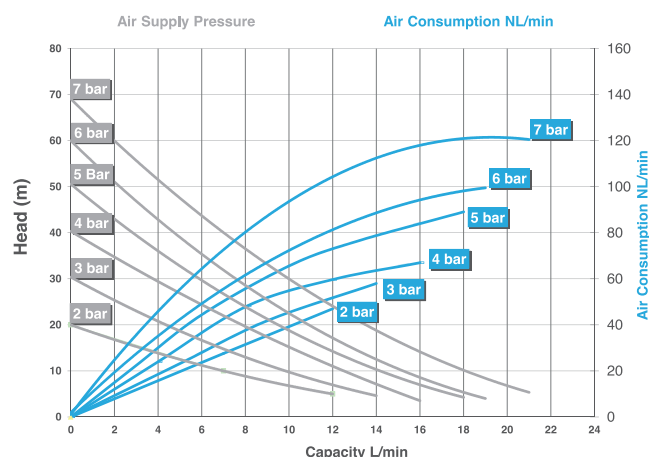

CONSTRUCTION MATERIALS	PP, PVDF
DIAPHRAGM	PTFE + BACK UP NBR
INTAKE/DELIVERY CONNECTIONS	G 3/8"
AIR CONNECTION	3/8"
* MAX SELF-PRIMING CAPACITY	4 m
* MAX FLOW	21 L/m
MAX HEAD	70 m
MAX AIR SUPPLY PRESSURE	7 bar
MAX DIMENSIONS OF SOLIDS IN SUSPENSION (DIAMETER)	0.5 mm
MAX OPERATING TEMPERATURE	PP 60°C PVDF 95°C
WEIGHT	PP 1.2 kg PVDF 1.9 kg

* The performance values refer to pumps with submerged suction and a free delivery outlet with water at 20°C at sea level. For other liquids please contact GemmeCotti srl. The values can change according to the material of construction.



AIR-OPERATED DOUBLE DIAPHRAGM PUMPS

HAOD 55

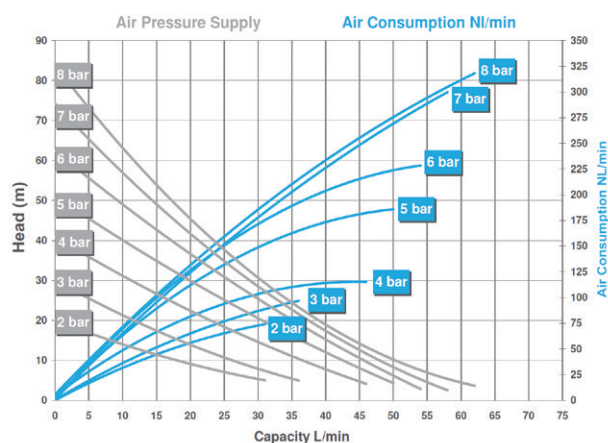

HAOD 100

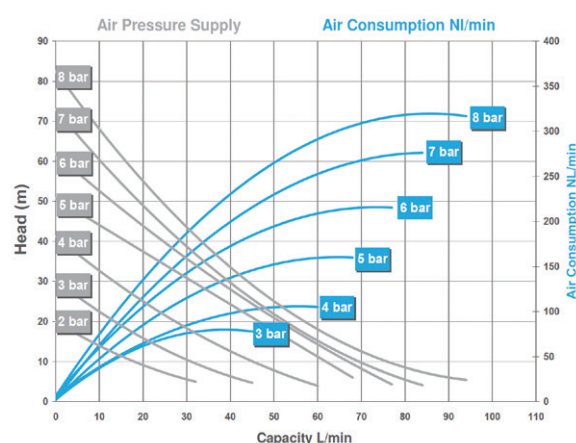

CONSTRUCTION MATERIALS	PP, PVDF, AISI 316
DIAPHRAGM	PTFE with EPDM
INTAKE/DELIVERY CONNECTIONS	G 1/2"
AIR CONNECTION	1/2"
* MAX SELF-PRIMING CAPACITY	3 m
* MAX FLOW	58 L/m
MAX HEAD	70 m
MAX AIR SUPPLY PRESSURE	8 bar
MAX DIMENSIONS OF SOLIDS IN SUSPENSION (DIAMETER)	3.0 mm
MAX OPERATING TEMPERATURE	PP 60°C PVDF 95°C AISI 316 95°C
WEIGHT	PP 4.0 kg PVDF 5.5 kg AISI 316 6.0 kg

CONSTRUCTION MATERIALS	PP, PVDF, AISI 316
DIAPHRAGM	PTFE with EPDM
INTAKE/DELIVERY CONNECTIONS	G 3/4"
AIR CONNECTION	1/2"
* MAX SELF-PRIMING CAPACITY	3 m
* MAX FLOW	95 L/m
MAX HEAD	80 m
MAX AIR SUPPLY PRESSURE	8 bar
MAX DIMENSIONS OF SOLIDS IN SUSPENSION (DIAMETER)	3.0 mm
MAX OPERATING TEMPERATURE	PP 60°C PVDF 95°C
WEIGHT	PP 4.0 kg PVDF 5.5 kg

* The performance values refer to pumps with submerged suction and a free delivery outlet with water at 20°C at sea level. For other liquids please contact GemmeCotti srl. The values can change according to the material of construction.

* The performance values refer to pumps with submerged suction and a free delivery outlet with water at 20°C at sea level. For other liquids please contact GemmeCotti srl. The values can change according to the material of construction.



HAOD 150



HAOD 300

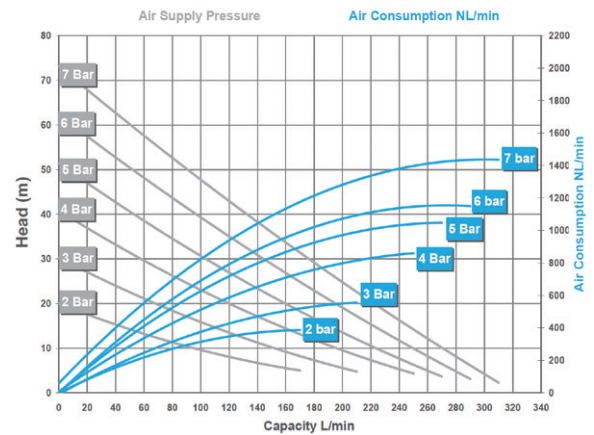
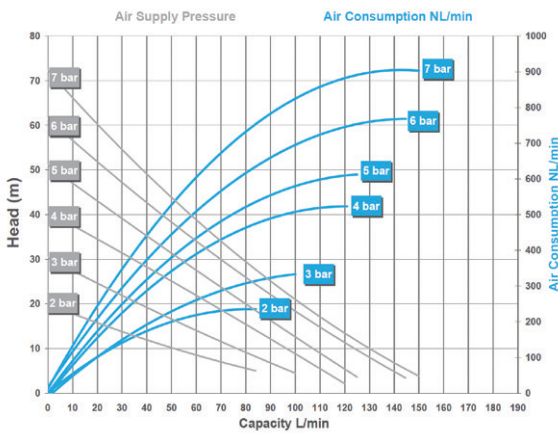

CONSTRUCTION MATERIALS	PP, PVDF, AISI 316
DIAPHRAGM	PTFE with EPDM
INTAKE/DELIVERY CONNECTIONS	G 1"
AIR CONNECTION	1/2"
* MAX SELF-PRIMING CAPACITY	4 m
* MAX FLOW	150 L/m
MAX HEAD	70 m
MAX AIR SUPPLY PRESSURE	7 bar
MAX DIMENSIONS OF SOLIDS IN SUSPENSION (DIAMETER)	3,5 mm
MAX OPERATING TEMPERATURE	PP 60°C PVDF 95°C AISI 316 95°C
WEIGHT	PP 6.0 kg PVDF 7.0 kg AISI 316 14.0 kg

CONSTRUCTION MATERIALS	PP, PVDF, AISI 316
DIAPHRAGM	PTFE with EPDM
INTAKE/DELIVERY CONNECTIONS	G 1 1/2"
AIR CONNECTION	1/2"
* MAX SELF-PRIMING CAPACITY	4 m
* MAX FLOW	310 L/m
MAX HEAD	70 m
MAX AIR SUPPLY PRESSURE	7 bar
MAX DIMENSIONS OF SOLIDS IN SUSPENSION (DIAMETER)	5.0 mm
MAX OPERATING TEMPERATURE	PP 60°C PVDF 95°C AISI 316 95°C
WEIGHT	PP 14.0 kg PVDF 22.0 kg AISI 316 30.0 kg

* The performance values refer to pumps with submerged suction and a free delivery outlet with water at 20°C at sea level. For other liquids please contact GemmeCotti srl. The values can change according to the material of construction.

* The performance values refer to pumps with submerged suction and a free delivery outlet with water at 20°C at sea level. For other liquids please contact GemmeCotti srl. The values can change according to the material of construction.



ATEX PUMPS AISI 316 ZONE 1 / 2



For applications in potentially explosive atmospheres, **GemmeCotti offers ATEX certified pumps**. ATEX pumps made of **metallic material AISI 316** are suitable to be used in **potentially explosive atmospheres classified zone 1 II 2G c Tx** and **zone 2 II 3G c Tx**.

All our ATEX pumps comply with the technical and safety requirements of ATEX Directive 2014/34/EU.



Pump model **EM-T made of AISI 316** - for **ATEX zone 1 and 2** (See pump model HTA page 32)



- Metallic pumps made in stainless steel AISI 316.
- Capacity up to 7 m³/h.
- Head up to 76 mlc.

Pump model **EM-C made of AISI 316** – for **ATEX zone 1 and 2** (See pump model HTM SS316 page 24)

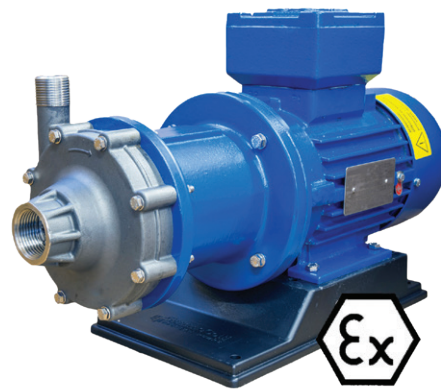

- Metallic pumps made in stainless steel AISI 316.
- Capacity up to 32 m³/h.
- Head up to 24 mlc.

Pump model **EM-P made of AISI 316** for **ATEX zone 1 and 2** (See pump model HTP page 38)

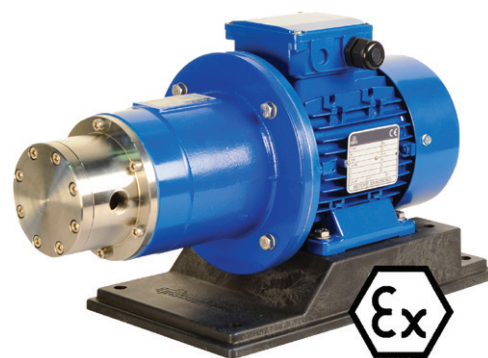

- Metallic pumps made in stainless steel AISI 316.
- Capacity up to 2100 L/h.
- Pressure up to 13 bar.
- Dry self-priming.



ATEX PUMPS PP/PVDF ZONE 2



For applications in potentially explosive atmospheres, **GemmeCotti offers ATEX certified pumps. ATEX pumps** made of thermoplastic material **polypropylene (PP) or PVDF** are **suitable to be used in potentially explosive atmospheres classified zone 2 II 3G c Tx.**

All our ATEX pumps comply with the technical and safety requirements of ATEX Directive 2014/34/EU.

Pump model **EM-C PP/PVDF** – only for **ATEX zone 2**
(See pump model HTM PP/PVDF page 14)

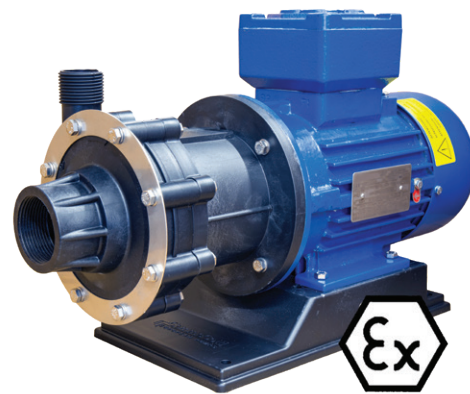

- Thermoplastic pumps made in PP or PVDF.
- Capacity up to 130 m³/h.
- Head up to 48 mlc.
- Injection molded parts.

Pump model **EM-C SP PP/PVDF** - only for **ATEX zone 2**
(See pump model HTM SP page 20)



- Thermoplastic pumps made in PP or PVDF.
- Capacity up to 25 m³/h.
- Head up to 22 mlc.

Pump model **EM-T PP/PVDF** - only for **ATEX zone 2**
(See pump model HTT page 28)

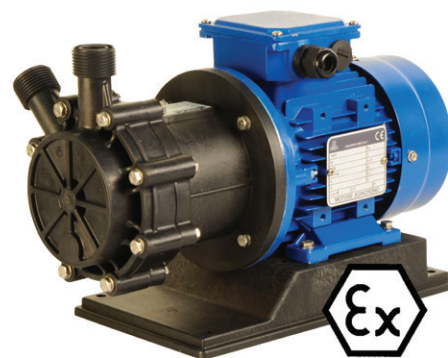

- Thermoplastic pumps made in PP or PVDF.
- Capacity up to 9 m³/h.
- Head up to 48 mlc.



Pump model **EM-P PP/PVDF** – only for **ATEX zone 2**
(See pump model HPP/HPF page 36)



- Thermoplastic pumps made in PP or PVDF.
- Capacity up to 980 L/h.
- Pressure up to 5 bar.

Pump model **EM-T SP PP/PVDF** - only for **ATEX zone 2**
(See pump model HTT-SP page 30)

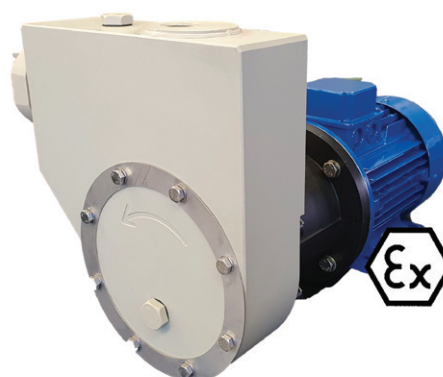

- Thermoplastic pumps made in PP or PVDF.
- Capacity up to 6 m³/h.
- Head up to 24 mlc.
- Machined from a block.
- Self-priming up to 5 m.

Pump model **EM-CO PP/PVDF** - only for **ATEX zone 2**
(See pump model HCO page 42)

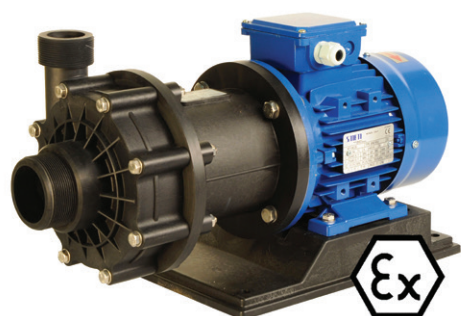

- Thermoplastic pumps made in PP or PVDF.
- Capacity up to 130 m³/h.
- Head up to 48 mlc.
- Mechanical seal.



FLANGES

GemmeCotti pumps are usually supplied with **threaded connections**. Upon request we can also supply **DIN or ANSI flanges for thermoplastic pumps** (flat stub + free flange) and welded **DIN or ANSI flanges for AISI 316 pumps**.

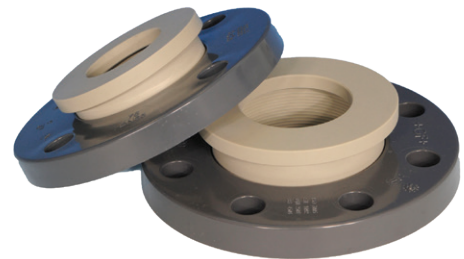
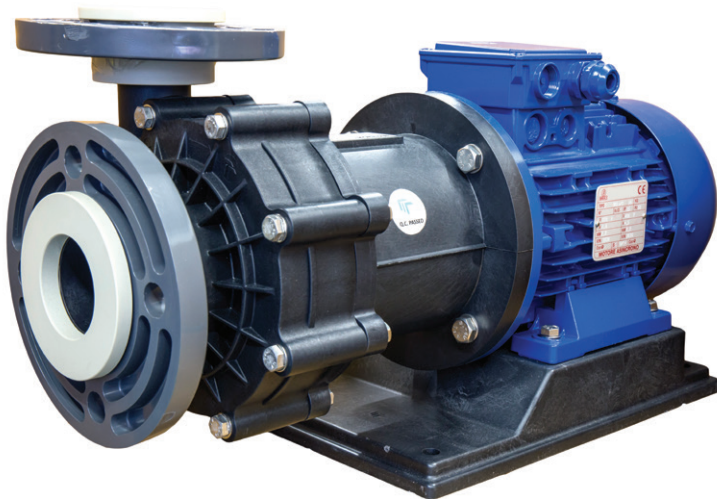
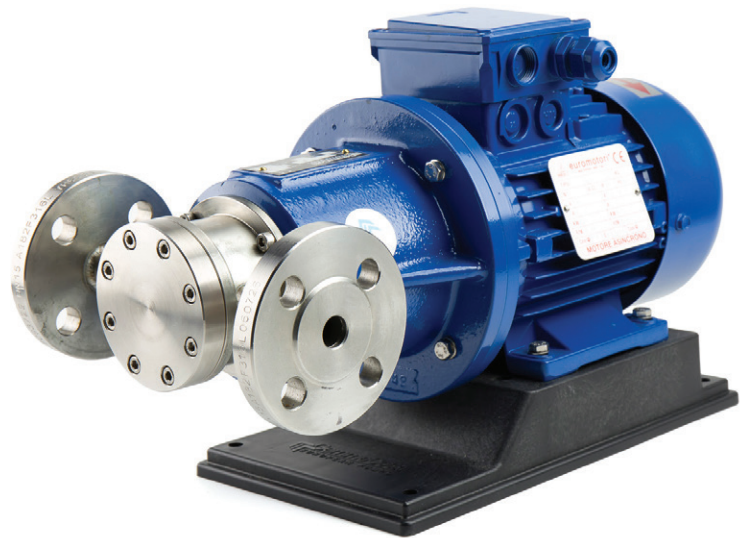

WE AND RWE KIT OF SPARE PARTS

GemmeCotti provides WE (Wet end) and RWE (Rear wet end) **spare parts kits for mag drive pumps**. These kits include the spare parts in contact with the fluid.

You can contact the GemmeCotti sales team to find out the best spare parts kit suitable for your pump, your specific application and pump use.

For magnetic drive centrifugal pumps model HTM PP/PVDF (HTM 4 PP/PVDF, HTM 6 PP/PVDF, HTM 10 PP/PVDF, HTM 15 PP/PVDF, HTM 31 PP/PVDF, HTM 40 PP/PVDF, HTM 50 PP/PVDF, HTM 80 PP/PVDF and HTM 100 PP/PVDF) the kits include mainly:

WE SPARE PARTS KIT:

- Pump head
- O-ring
- Casing thrust bush
- Shaft & ring
- Impeller thrust bearing
- Impeller
- Internal magnet
- Bearing
- Rear casing

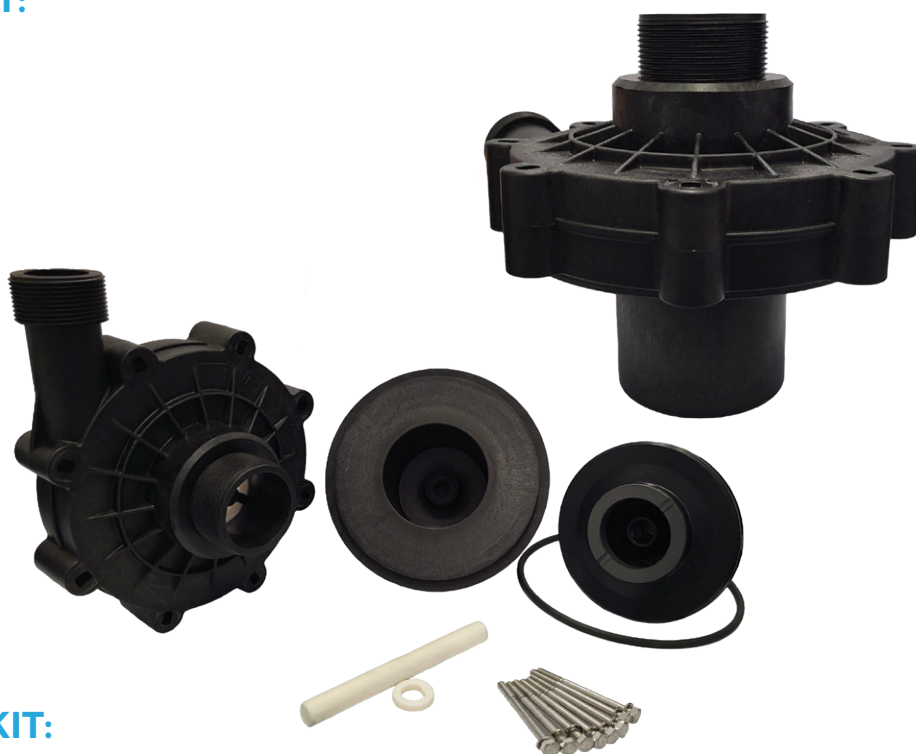

RWE SPARE PARTS KIT:

- O-ring
- Casing thrust bush
- Shaft & ring
- Impeller thrust bearing
- Impeller
- Internal magnet
- Bearing
- Rear casing





BASEPLATES

The pump complete with the motor can be installed perfectly horizontal thanks to our baseplates. GemmeCotti Baseplates for horizontal pumps are **made of PP (Polypropylene)** and they are **suitable for motors B3/B5 IEC** and **NEMA** from 0,12 kW to 4 kW. The baseplates are available in **three different dimensions** (type "A", type "B" and type "C").

MATERIAL

- PP

DIMENSION AVAILABLE

Available in three different dimensions:

- **BASEPLATE TYPE "A"** suitable for: IEC motors B3/B5 from size 56 to size 71
- **BASEPLATE TYPE "B"** suitable for: IEC motors from size 80 to size 90 and NEMA motors 56TC and 145T.
- **BASEPLATE TYPE "C"** suitable for: IEC motors from size 100 to size 112 and NEMA motors 184T.



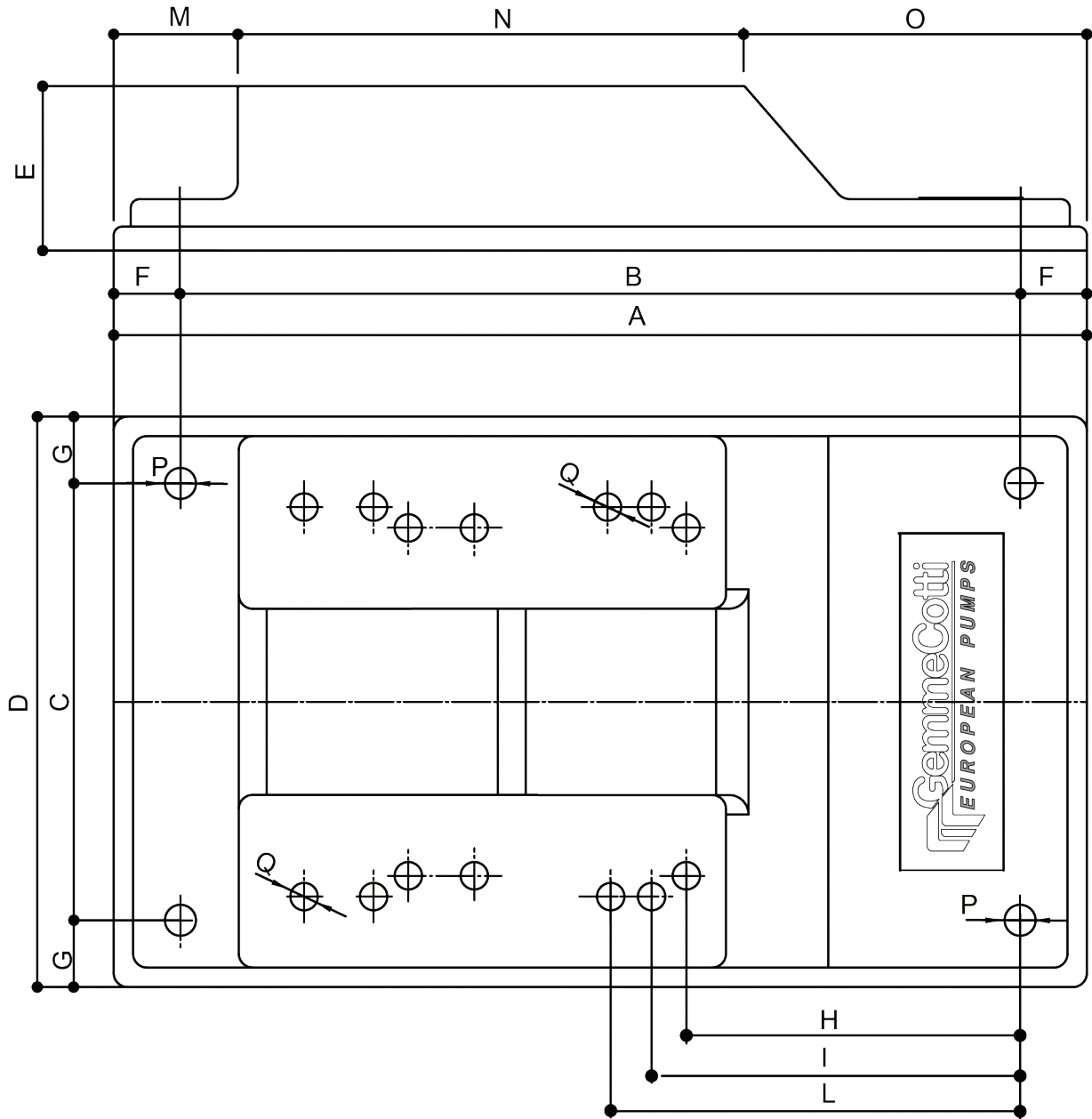

TYPE	MOTOR	DIMENSIONS - mm -															
		A	B	C	D	E	F	G	H	I	L	M	N	O	P	Q	
A	IEC-GR. 56 IEC-GR. 63 IEC-GR. 71	280	244	130	160	48	18	15	94	103	112	29	151	100	8	8	
B	IEC-GR. 80 IEC-GR. 90 NEMA-GR. 56TC NEMA-GR. 145T	350	302	157	205	60	24	24	120	132	-	45	175	130	12	11	
C	IEC-GR. 100 IEC-GR. 112 NEMA-GR. 184T	400	352	202	250	60	24	24	140	156	-	45	210	145	12	12	



DRY-RUNNING PROTECTION DEVICE

To prevent damages to the pumps due to the lack of liquid, GemmeCotti supplies the dry-running protection device. This device **avoids the dry running, the closed discharge and the blocked suction**. Thanks to the adjustable threshold and timer, it is possible to set up the minimum power and operation time of the device. If the power is lower than the set value, the pump will automatically stop. This device is particularly **recommended during the operations of tanker unloading and for all the applications in which there is the risk of liquid shortage**.



MAIN FEATURES

- Single Phase CURRENT RELAY
- Multirange 15-35A
- 2 set points MAX / min
- Also for motors with INVERTER

SUCTION STRAINER

GemmeCotti can supply **suction strainers** as an accessory for vertical pumps. The suction strainer has a **length of 200mm** and can be tightened to the pump suction port.

Suction strainers protect pumps from contamination trapping coarse impurities and they prevent solids present in the liquid or at the bottom of the tank or sump from entering the pump.



PT 100 THERMOPROBE

For pumps installed in ATEX zone 1 II 2G areas, GemmeCotti can offer the **PT 100 thermoprobe**, a high-precision temperature sensor specifically designed for accurate monitoring of mag-drive pump operating temperatures.



DIAPHRAGM SEAL PRESSURE GAUGE

GemmeCotti offers **diaphragm seal pressure gauges in Polypropylene and PVDF**, designed to protect pressure measuring instruments from harsh process conditions.



BOLTS AND NUTS

GemmeCotti also supplies a variety of **bolts and nuts**:

BOLTS:

- **M16x110**
Max tightening torque: 15 Nm
Material: PVDF
- **M12x50**
Max tightening torque: 7 Nm
Material: PVDF
- **M10x25**
Max tightening torque: 4.5 Nm
Material: PVDF

NUTS:

- **M16** Material: PVDF
- **M12** Material: PVDF
- **M10** Material: PVDF





CHEMICAL COMPATIBILITY CHART

LEGEND:

A = Very good | **B** = Good | **C** = Poor, not recommended | **D** = Very poor, not recommended
1 = Good until 22°C (72°F) | **2** = Good until 48°C (120°F)

CHEMICAL	FORMULA	PUMP MATERIALS			O-RING MATERIALS		
		PP	PVDF	AISI 316	EPDM	Viton	V/FEP*
ACETIC ACID	CH ₃ COOH	B	C	B	A	B	A
ACETIC ACID 20%	CH ₃ COOH	A	A	A	A2	B	A
ACETIC ACID 60%	CH ₃ COOH	A	B	B	A	D	A
ACETIC ACID, GLACIAL	CH ₃ COOH	A1	A1	A	D	D	A
ACETONE	CH ₃ COCH ₃	A	D	A	A	D	A
ADBLUE	CO(NH ₂) ₂	A	A	A	A	C	A
ALCOHOLS:ETHYL	CH ₃ CH ₂ OH	A	A	A	A	A	A
ALCOHOLS:ISOPROPYL	(CH ₂) ₂ CHOH	A	A	B	A	A	A
ALCOHOLS:METHYL	CH ₂ OH	A	A	A	A	C	A
ALCOHOLS:PROPYL	C ₂ H ₅ OH	A	A	A	A	A	A
ALUMINUM SULFATE	Al ₂ (SO ₄) ₃	A	A	C	A	A	A
AMMONIA, LIQUID	NH ₃	A	D	A2	A	D	A
CHLORINE, ANHYDROUS LIQUID	Cl ₂	D	A2	D	C	A	A
CHLOROFORM		C1	A	A	D	A	A
CHROMIC ACID < 50%	H ₂ CrO ₄	C	A	D	C	A	A
COPPER CHLORIDE	CuCl ₂	A	A	D	A	A	A
COPPER SULFATE > 5%	CuSO ₄	A	A	A	A	A	A
DETERGENTS		A	A	A2	A	A	A
DIESEL FUEL		C	A	A1	D	A	A
ETHYL ACETATE		A1	D	B	B	D	A
FERRIC CHLORIDE	FeCl ₃	A	A	D	A	A	A
FORMALDEHYDE 100%	HCHO	A	A	A	A	A	A
FUEL OILS		C	A	A	D	A	A
GASOLINE (HIGH-AROMATIC)	C12H26	D	A	A	D	A	A
GLUCOSE	C ₆ H ₁₂ O ₆	A	A	A	A	A	A
HYDRAULIC OIL (PETRO)		A1	A	A	D	A	A
HYDROCHLORIC ACID <33%	HCl	A2	A	D	A2	A	A
HYDROFLUORIC ACID 50%	HF	D	A	D	D	A	A
HYDROGEN PEROXIDE 10%	H ₂ O ₂	A	A	B	A	A	A
HYDROGEN PEROXIDE 30%	H ₂ O ₂	B1	A	B	B	A	A
KEROSENE		A	B	A	D	A	A

*Viton/FEP

All the information in this chart is only approximate and should only be used for an initial choice of the type of materials best suited for the customers' pumps. The data comes from various highly reliable sources. Despite this, GemmeCotti itself did not carry out the relative tests, and is not responsible for the preciseness of the data. Therefore, GemmeCotti has no responsibility for possible malfunctions or damage of any type caused by the incorrect selection of construction materials and/or of the incorrect choice of pump size if it is not made by GemmeCotti itself after having received all suitable information regarding the application and the characteristics of the pumped liquid.

CHEMICAL	FORMULA	PUMP MATERIALS			O-RING MATERIALS		
		PP	PVDF	AISI 316	EPDM	Viton	V/FEP*
NAPHTHA		A1	A	A	D	A	A
NICKEL CHLORIDE	NiCl ₂	A	A	C	A	A	A
NITRIC ACID < 50%	HNO ₃	D	A	A1	D	A	A
OLIVE OIL		A	A	A	D	A	A
PHENOL (CARBOLIC ACID)	C ₆ H ₅ OH	A2	A2	B	B	A	A
POTASSIUM PERMANGANATE	KMnO ₄	A1	A	B	A	A	A
PHOSPHORIC ACID < 40%	H ₃ PO ₄	A	A	C	A	A	A
PHOSPHORIC ACID > 40%	H ₃ PO ₄	A	A	D	A	A	A
PHOTOGRAPHIC DEVELOPER		A	-	A	B	A	A
POTASSIUM CYANIDE	KCN	A	A	A	A	A	A
PROPYPLENE GLYCOL	C ₃ H ₈ O ₂	A	A	B	A	A	A
RESINS		A2	-	A1	-	A	A
SALT BRINE		A	A	C	A	A	A
SEA WATER		A	A	C	A	A	A
SOAP SOLUTIONS		A	A	A	A	A	A
SODIUM BICARBONATE	NaHCO ₃	A	A	A	A	A	A
SODIUM BISULFITE	NaHSO ₃	A	A	A1	A	A	A
SODIUM CHLORIDE	NaCl	A	A	A2	A	A	A
SODIUM HYDROXIDE (10%)	NaOH	A	C	A	A	C	A
SODIUM HYDROXIDE (40%)	NaOH	A	C	A	A	C	A
SODIUM HYDROXIDE (50%)	NaOH	A	D	A	A	D	A
SODIUM HYPOCHLORITE 12,5%	NaOCl	C	A	C	C	A	A
SULFURIC ACID (10-75%)	H ₂ SO ₄	A	A	D	C	A	A
SULFURIC ACID (75-98%)	H ₂ SO ₄	D	A	C	D	A	A
TOLUENE (TOLUOL)	C ₆ H ₅ CH ₃	C	A	A	D	A	A
UREA	CH ₂ N ₂ O	A	A	B	A	A	A
WATER, ACID, MINE	H ₂ O	A	A	B	A	A	A
WATER, DISTILLED	dH ₂ O	A	A	A	A	A	A
XYLENE	C ₈ H ₁₀	D	A	B	D	C	A
ZINC CHLORIDE	ZnCl ₂	A	A	B	A	A	A



www.gemmecotti.com



Ph: +39 02.96460406



info@gemmecotti.com

Follow us:





GEMMECOTTI SRL

Via Po 23-25-27
20031 Cesate MILANO | ITALY
EUROPEAN UNION

Ph: +39 02.96460406
info@gemmecotti.com



www.gemmecotti.com

